

SLM6+SLMT6

(D)	MONTAGEANLEITUNG:	DREHTÜR 1-TLG. IN DER HÄLFTE GETEILTE + SEITENWAND IM 90°-WINKEL
(GB)	INSTALLATION INSTRUCTIONS:	PIVOT DOOR DIVIDED IN THE MIDDLE + FIXED PANEL AT 90°
(F)	NOTICE DE MONTAGE:	DOUBLE PORTE PIVOTANTE DE MI-HATEUR + PAROI FIXE
(CZ)	NÁVOD K MONTÁŽI:	JEDNOKŘÍDLÉ DVEŘE V POLOVINĚ ROZDĚLENÉ + BOČNÍ STĚNA v 90°
(PL)	INSTRUKCJA MONTAŻU:	DRZWI OBROTOWE 2-CZEŚCIOWE DZIELONE W POŁOWIE + ŚCIANKA BOCZNA
(SK)	NÁVOD NA MONTÁŽ:	JEDNOKRÍDLOVÉ DVEŘE V 1/2 ROZDELENÉ + BOČNÁ STĚNA V 90°
(H)	SZERELÉSI ÚTMUTATÓ:	NÝLÓAJTÓ FÉLMAGASSÁGBAN KETTÉ OSZTVA + OLDALFAL 90°-BAN
(E)	INSTRUCCIONES DE MONTAJE:	PUERTA EN 1/2 DIVIDIDA EN TRES + PARED LATERAL DE 90°
(RO)	INSTRUCȚIUNI DE MONTAJ:	UȘĂ PIVOTANTĂ DINTR-O BUCATĂ ÎMPĂRȚITĂ LA JUMĂTATE + PERETE LATERAL 90°



SanSwiss®
RONAL GROUP

Benötigtes Werkzeug:

Necessary tools:

Outil Nécessaire:

Nářadí potřebné pro montáž:

Potrzebne narzędzia:

Potrebne náradie:

Szükséges szerszámok:

Herramientas necesarias:



2x

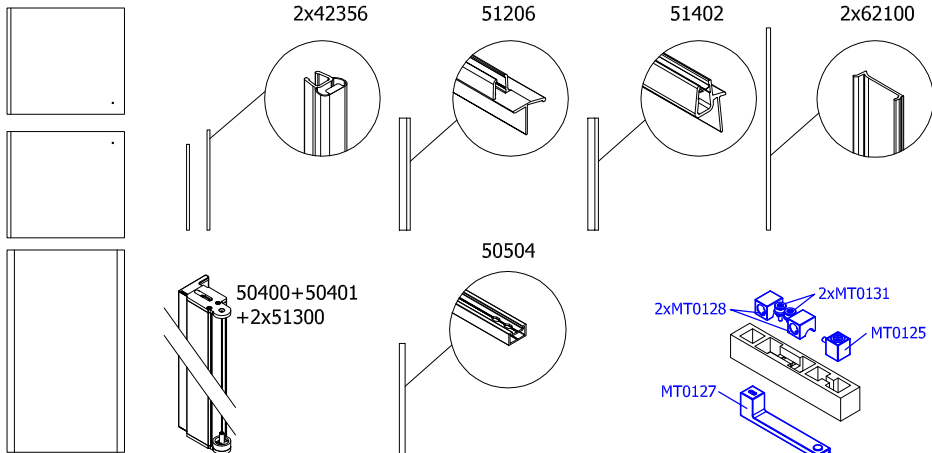
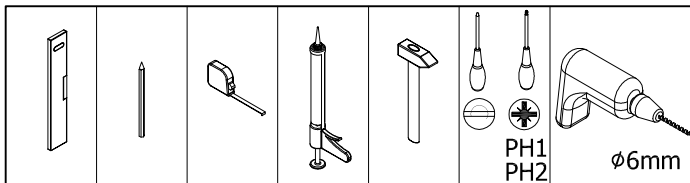

Zubehör:

Equipment:

Accessoires:

Příslušenství:

Dodatki:

Príslušenstvo:

Alkatrészek:

Accesorios:

SLM6	 1 x 11221	 1 x 14016 3.5 x 22mm	 2 x 14006 3.5 x 25mm	 1 x 14027 M4 x 25mm	 3 x 14118 4.2 x 32mm	 4 x 14214 M4 x 6mm
	 3 x 16000 6mm	 3 x 51317	 1 x 51610 + 1 x 51611	 1 x 54401	 1 x 54408 + 1 x 54409	

SLMT6	 2 x 14006 3.5 x 25mm	 1 x 14016 3.5 x 22mm	 3 x 14118 4.2 x 32mm	 3 x 16000 6mm	 3 x 51209	 1x51232 1x51233	 2 x 51317	 1 x 51546 1 x 51547	 1x51798 + 1x51799
-------	-----------------------------	-----------------------------	-----------------------------	----------------------	---------------	------------------------	---------------	----------------------------	-----------------------

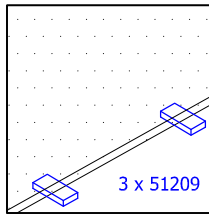
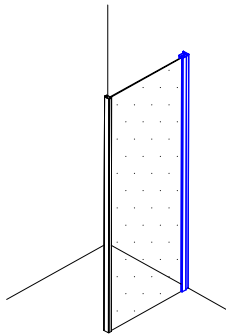

1.

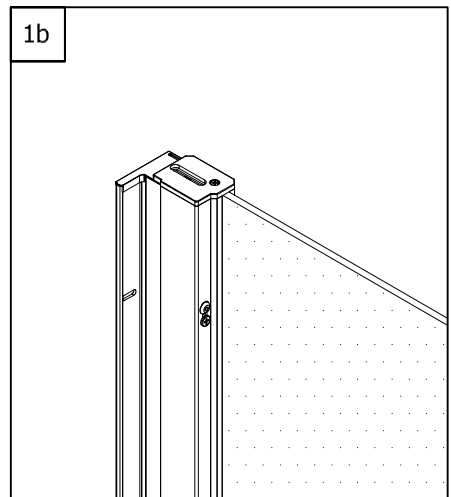
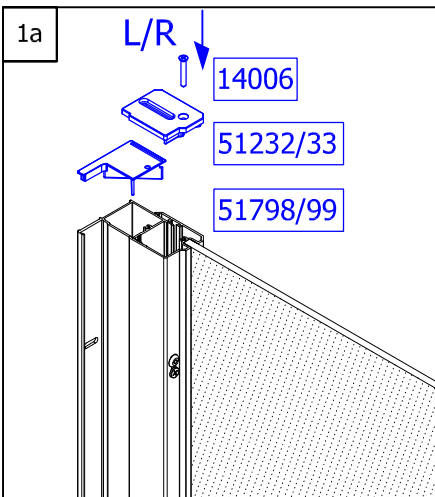

2.

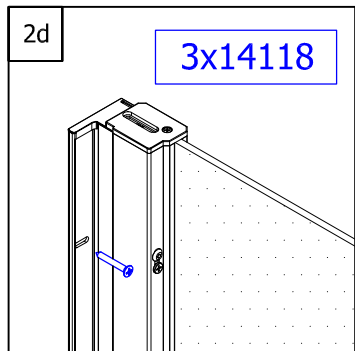
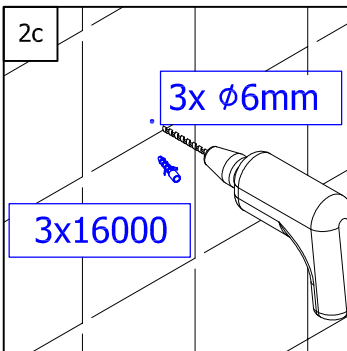
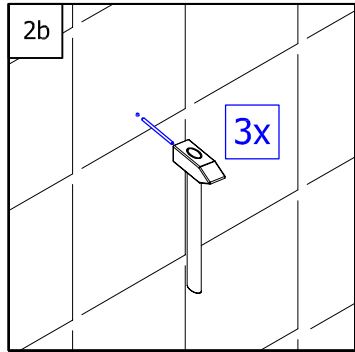
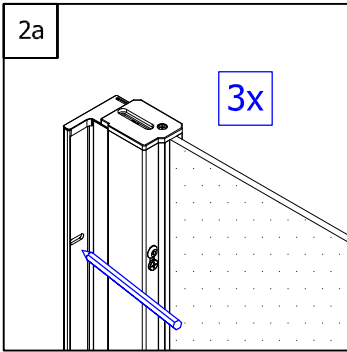
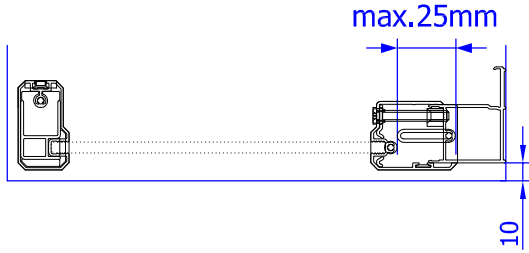
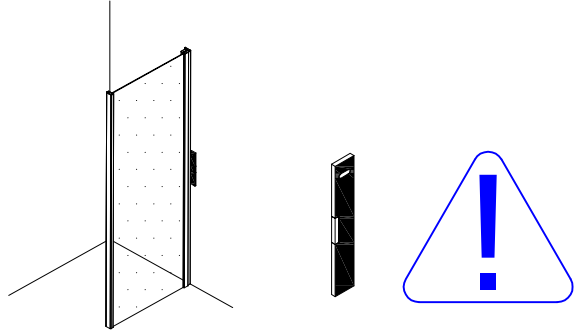

3a

50400+50401
+51300

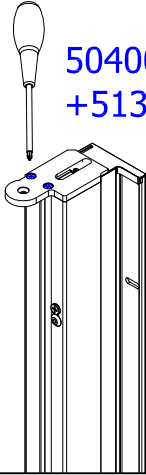

3b

50400+50401
+51300

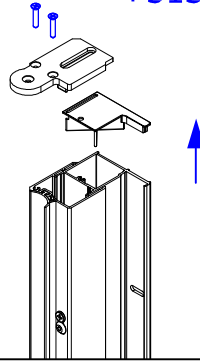

3c

51610/11+54408/09
+2x14006

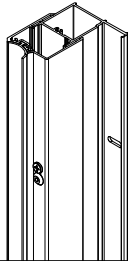
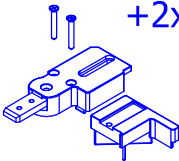

54402/03+51798/99



3d

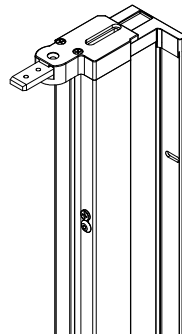

3.

4.

max.25mm
10

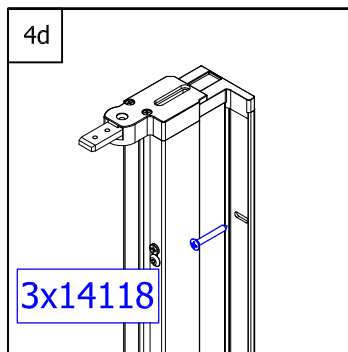
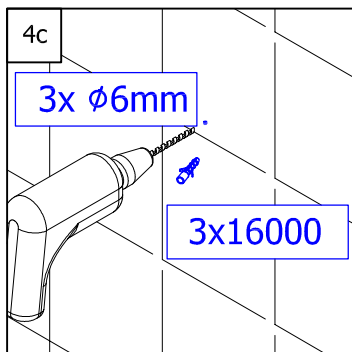
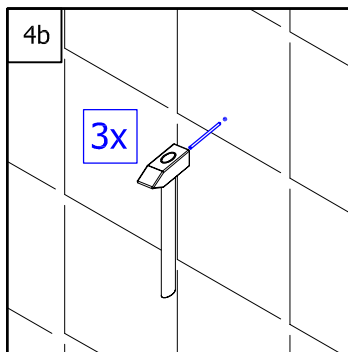
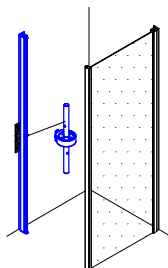
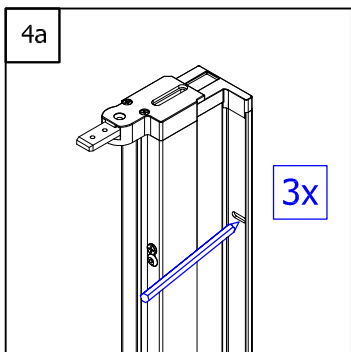

5.

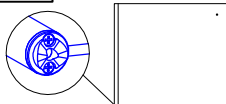
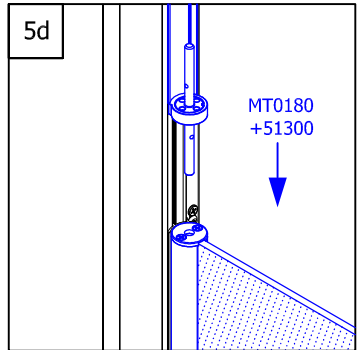
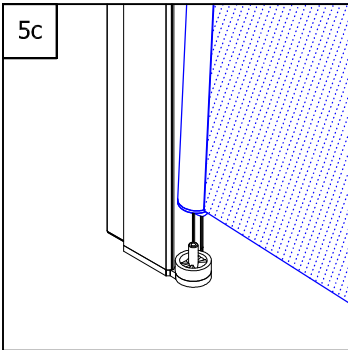
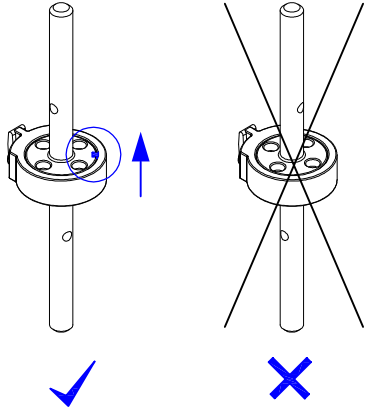
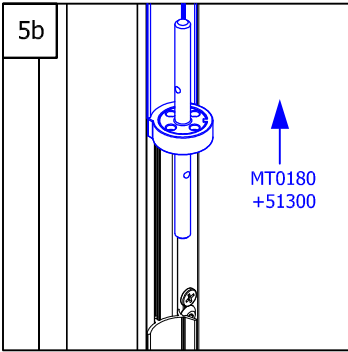
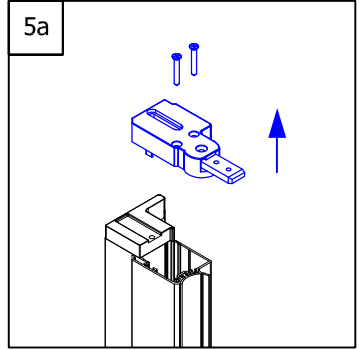
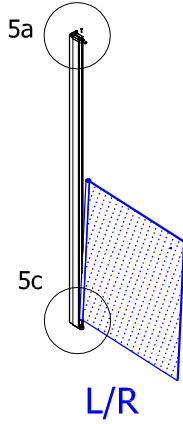

6.

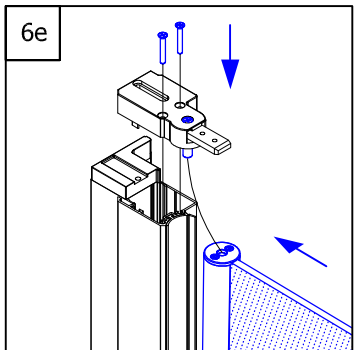
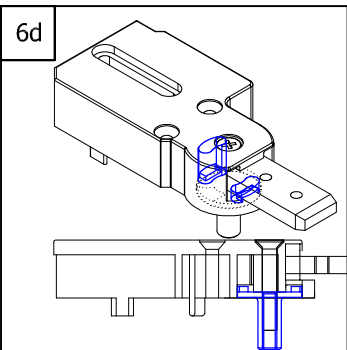
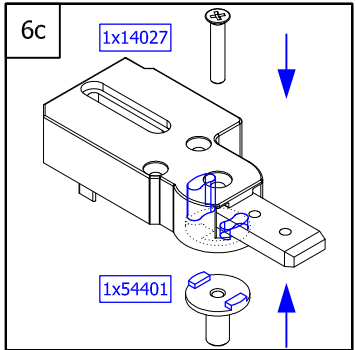
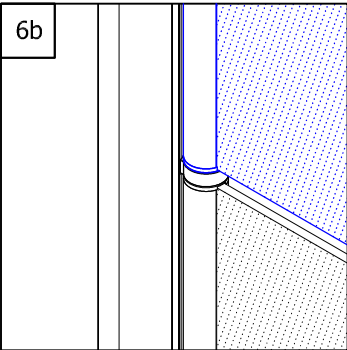
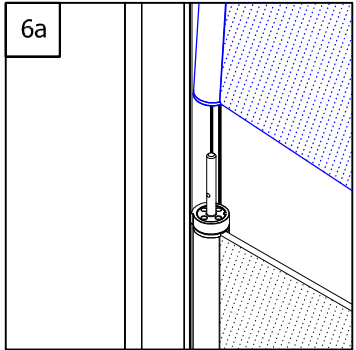
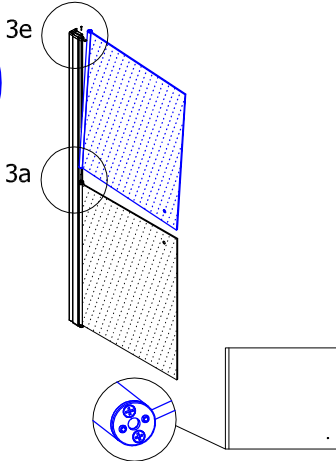

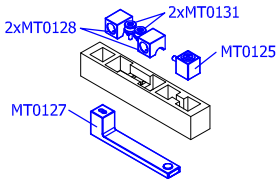

7.

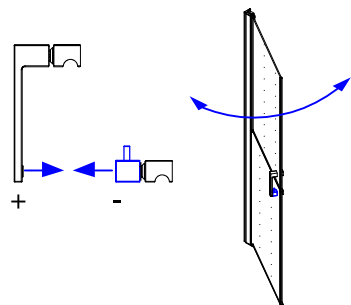
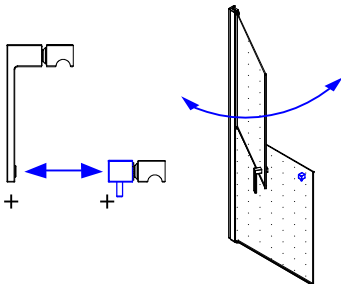
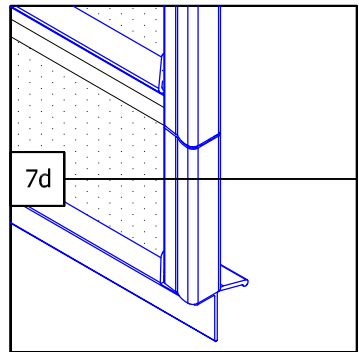
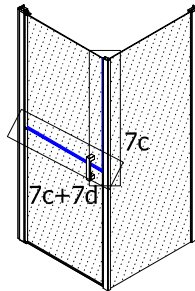
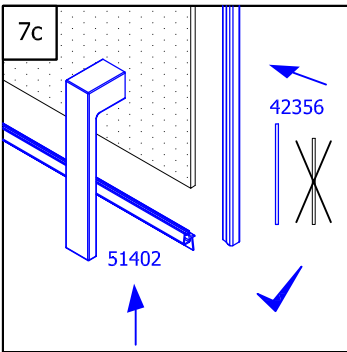
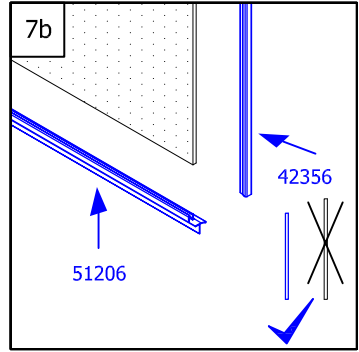
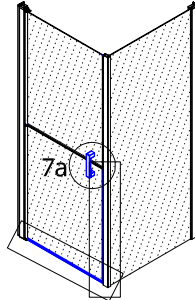
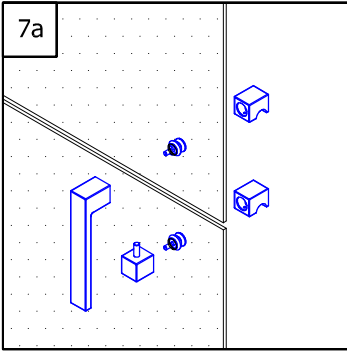

8.

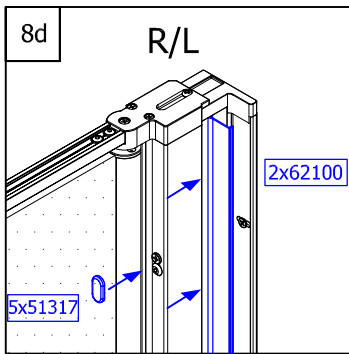
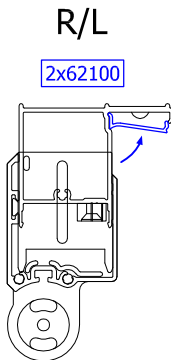
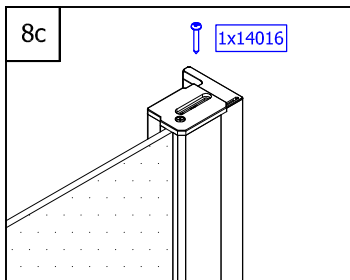
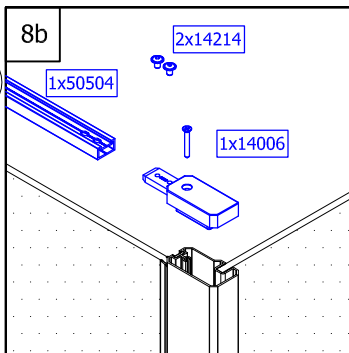
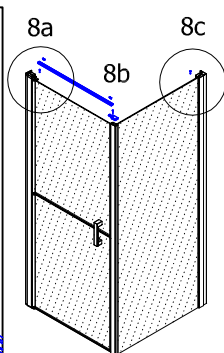
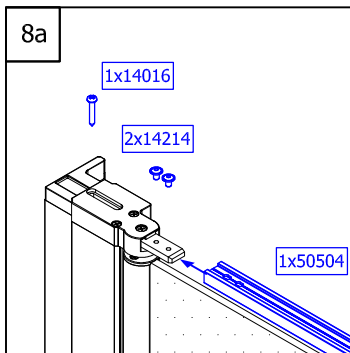
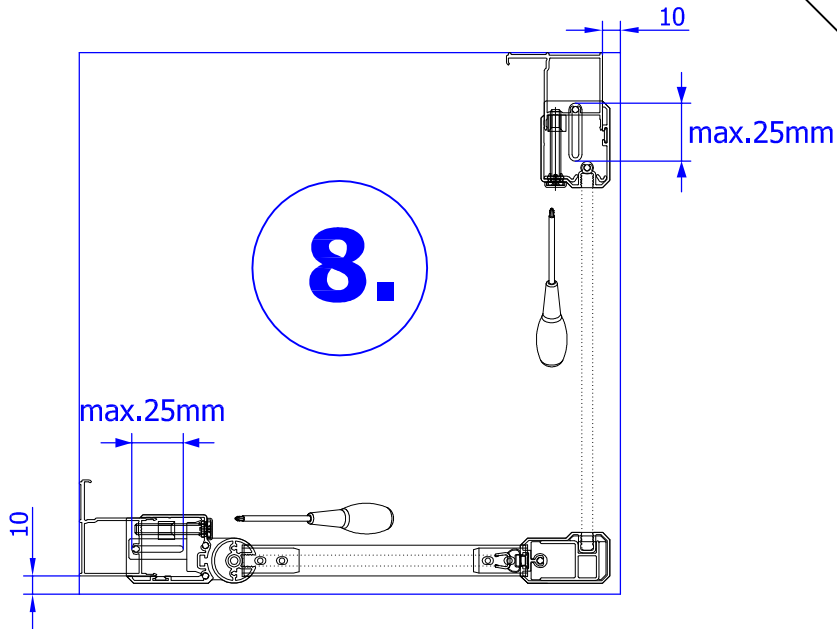

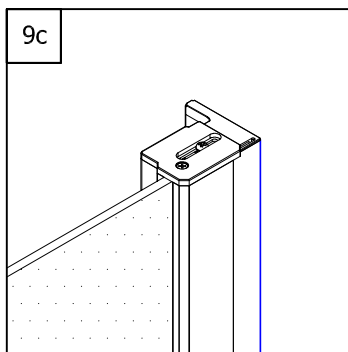
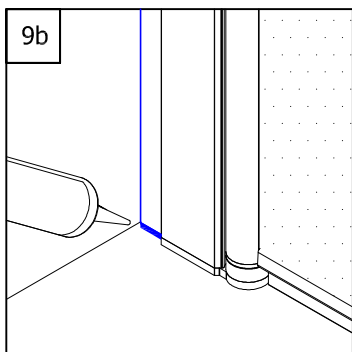
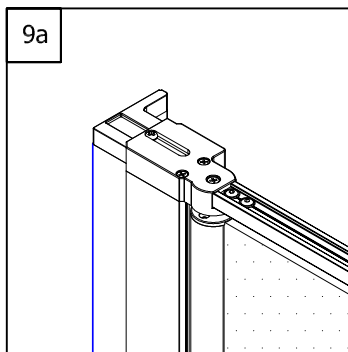
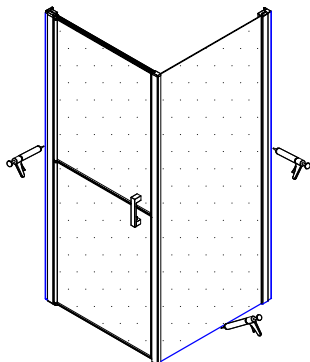

Achtung! Nur Sanitär-Silikon - bakterizid und fungizid eingestellt verwenden.

Caution! Use only bactericidal and fungicide sanitary silicone.

Attention! N'utiliser que du silicone sanitaire bactéricide et fongicide.

Pozor! Používejte pouze baktericidní a fungicidní sanitární silikon.

Uwaga! Stosować tylko silikon sanitarny - bakterio i grzybobójczy.

Pozor! Užívajte pouze baktericidný a fungicidný sanitárny silikón.

Figyelem! Csak szaniter sziloplaszt - baktérium és gombamentes - használata megengedett.

Cuidado! Utilizar solamente silicona sanitaria bactericida y fungicida.

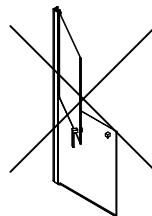
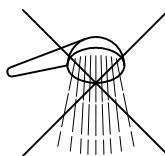

SLM6+SLMT6

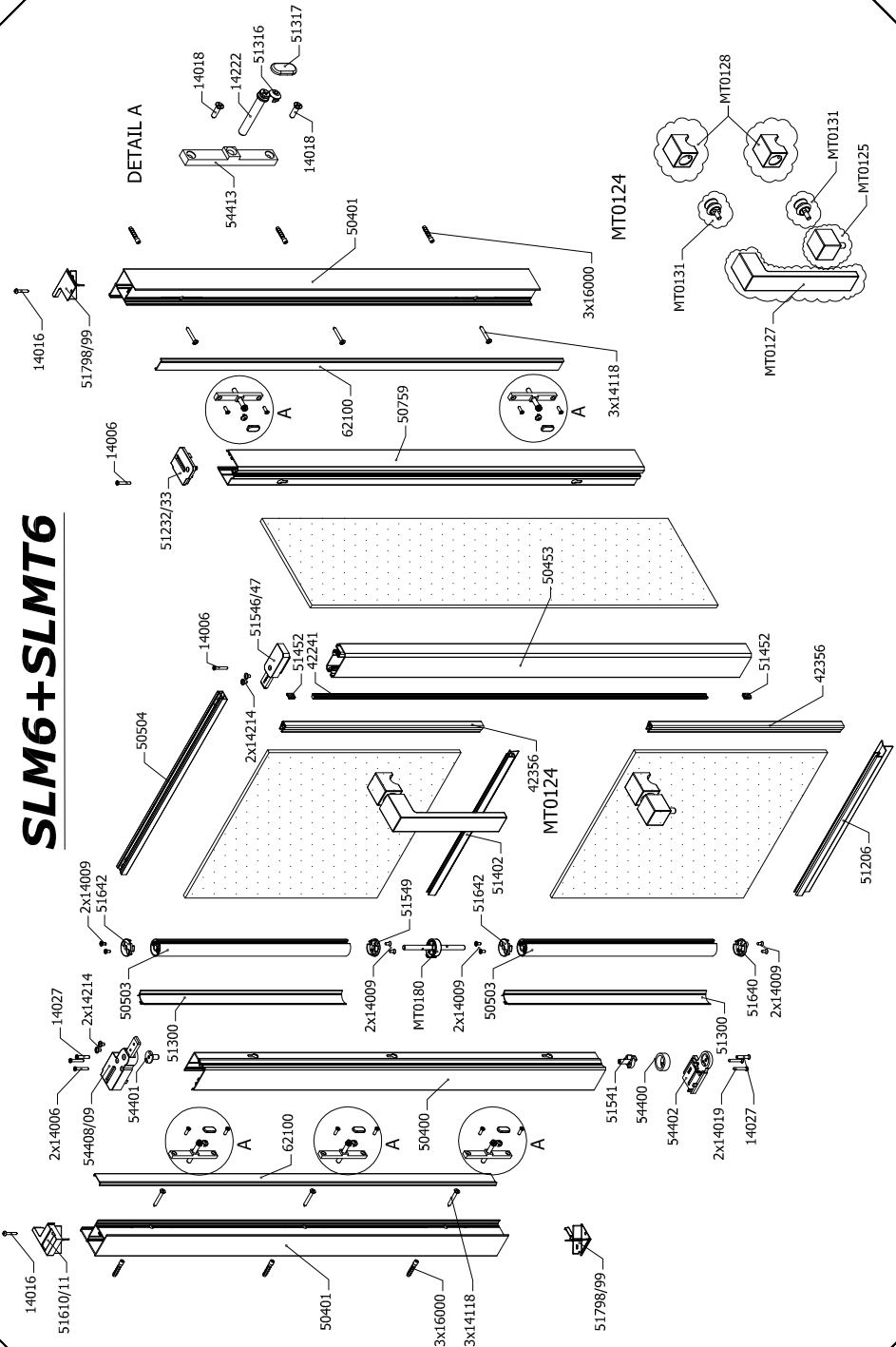

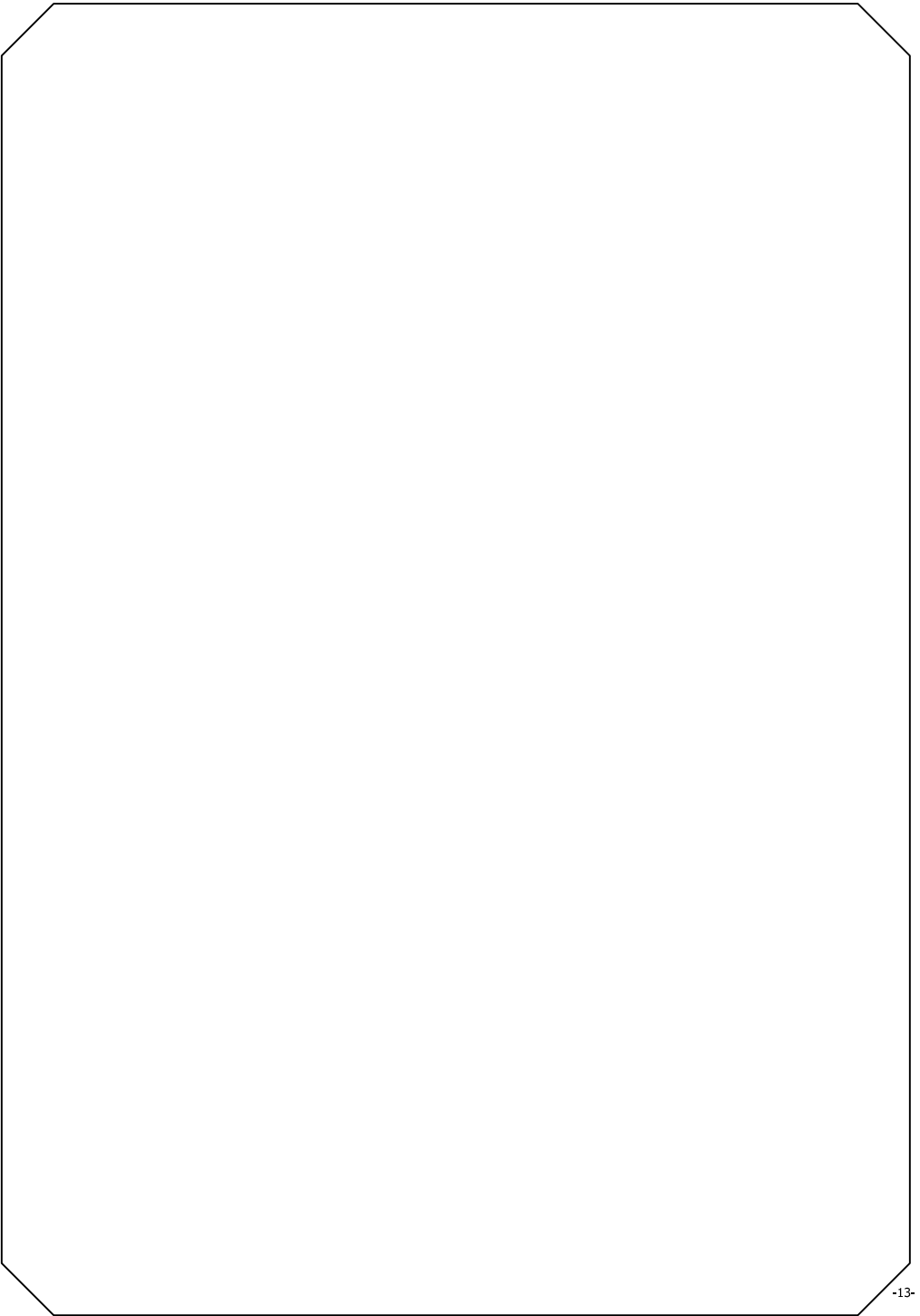

QUALITY CONTROL:

- D** Falls Sie Reklamationen haben, oder Sie unzufrieden mit Ihrem SANSWISS Produkt sind, beschreiben Sie bitte unten auf diesem Blatt den Produktfehler und übergeben Sie dieses Dokument Ihrem Verkäufer, oder direkt der Firma SANSWISS. Diese Information hilft uns, die Qualität von unseren Produkten weiter zu verbessern.
- GB** In case of a complaint or Your dissatisfaction with the SANSWISS product, please describe the defect below and pass this document to Your vendor, or directly to the SANSWISS company. This information will help us in the next increase of the quality of our products.
- F** En cas de réclamations lors de la livraison ou l'installation de votre paroi de douche SANSWISS, veuillez, s'il vous plaît, noter vos remarques au bas de la feuille et transmettre les informations à votre revendeur. Elles nous permettrons d'améliorer notre qualité et par la même notre service.
- CZ** V případě reklamace, či Vaší nespokojenosti s výrobkem SANSWISS popište prosím ve spodní části tohoto listu závadu a dokument prosím odevzdejte Vašemu prodejci nebo přímo firmě SANSWISS. Tato informace nám pomůže v dalším zvýšení kvality našich výrobků.
- PL** Reklamacje , oraz inne niezgoności związane z produktem SANSWISS prosimy przekazywać sprzedawcy na załącznym druku.
- SK** V prípade reklamácie, alebo Vašej nespokojnosti s výrobkom SANSWISS, popíšte prosím v spodnej časti tohto listu zá vadu a dokument prosím odovzdajte Vašemu prodejci, alebo priamo firme SANSWISS. Táto informácia nám pomôže v ďalšom zvýšení kvality našich výrobkov.
- H** Abban az esetben ha reklamációja vagy panasza van az Ön által vásárolt SANSWISS termékkel, úgy azt írja meg a lap alján található helyre és adja át a kereskedőjének, vagy küldje el közvetlenül a SANSWISS cégnek! Ez az információ segít nekünk termékeink minőségének javításában.
- E** En caso de reclamaciones ó si no está satisfecho con su producto SANSWISS, por favor describan en la parte inferior de esta hoja el fallo del producto y entreguen este documento a su vendedor ó directamente a la empresa SANSWISS. Esta información nos ayuda a seguir mejorando la calidad de nuestros productos.
- RO** În cazul în care aveți reclamații sau nemulțumiri legate de produsele SANSWISS, vă rugăm să descrieți defecțiunea și să transmiteți acest document vânzătorului sau direct firmei SANSWISS. Această informație ne ajută să îmbunătățim în continuare calitatea produselor noastre.

.....

.....

.....

.....

.....

.....