

SL2+SLT2

(D) MONTAGEANLEITUNG:	PENDELTÜR, 2-TEILIG + SEITENWAND
(GB) INSTALLATION INSTRUCTIONS:	DOOR WITH 2 PIVOT PANELS + FIXED PANEL
(F) NOTICE DE MONTAGE:	PORTE SALOON + PAROI FIXE
(CZ) NÁVOD K MONTÁŽI:	DVOUKŘÍDLÉ DVEŘE + BOČNÍ STĚNA
(PL) INSTRUKCJA MONTAŻU:	2-CZĘŚCIOWE DRZWI WAHAND ŁOWE
(SK) NÁVOD NA MONTÁŽ:	DVOJKRÍDLOVÉ DVERE + BOČNÁ STENA
(H) SZERELÉSI ÚTMUTATÓ:	LENG'O'AJTÓ 2-RÉSZES
(E) INSTRUCCIONES DE MONTAJE:	PUOERTA PIVOTANTE, 2 PIEZAS
(RO) INSTRUCȚIUNI DE MONTAJ:	UȘĂ BATANTĂ DIN 2 PIESE + PERETE LATERAL



ARONAL®

Benötigtes Werkzeug:

Necessary tools:

Outil Nécessaire:

Nářadí potřebné pro montáž:

Potrzebne narzędzia:

Potrebne náradie:

Szükséges szerszámok:

Herramientas necesarias:



1x

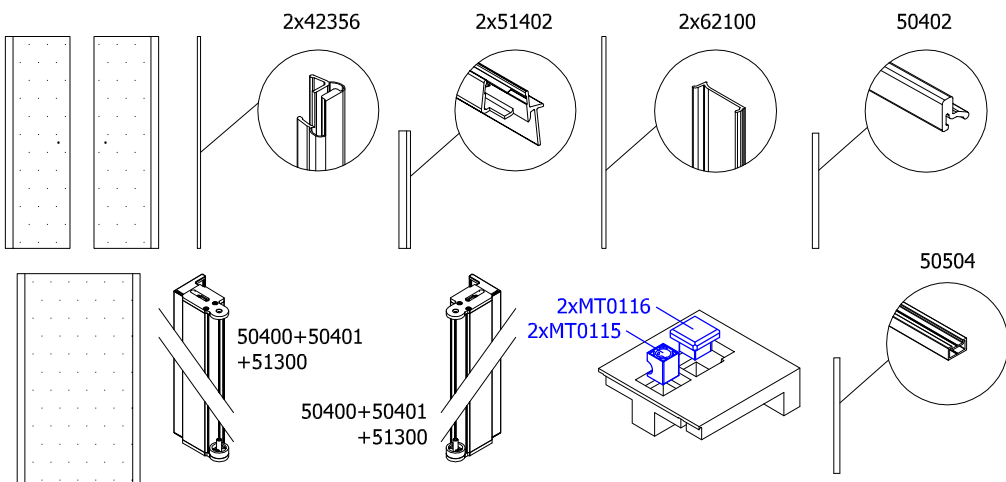
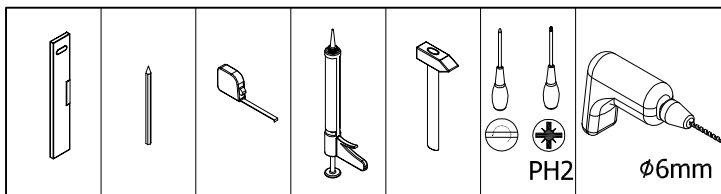

Zubehör:

Equipment:

Accessoires:

Příslušenství:

Dodatki:

Príslušenstvo:

Alkatrészek:

Accesorios:

SL2	 1 x 11221	 2 x 14016 3.5 x 22mm	 2 x 14027 M4 x 25mm	 6 x 14118 4.2 x 32mm	 6 x 16000 ø 6mm	 4 x 51317
	 1 x 51695+1 x 51696	 2 x 54401	 2 x MT0117			

SLT2	 4 x 14214 M4 x 6mm	 5 x 14006 3.5 x 25mm	 1 x 14016 3.5 x 22mm	 2 x 51317	 3 x 51209	 1 x 51232+1 x 51233	 1 x 51606+1 x 51607
	 1 x 51608+1 x 51609	 1 x 51610+1 x 51611	 1 x 51798+1 x 51799	 1 x 54408+1 x 54409			

1a

50401+50400
+51300

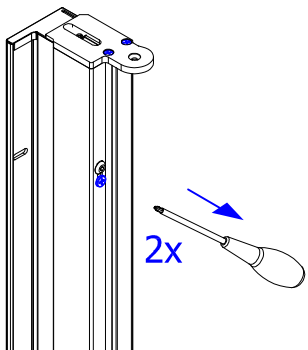

1b

50401+50400+
51798/99

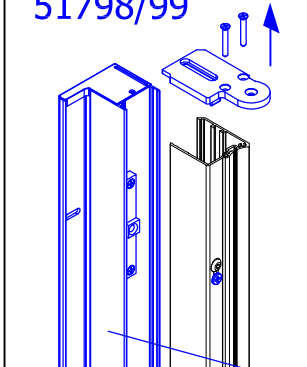

1c

L/R

14006

51232/33

51798/99

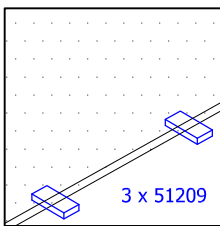
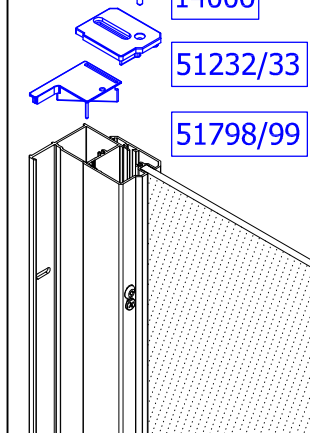

1d



50401

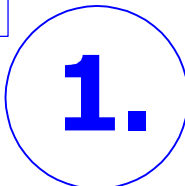

1e

1d

51608/09

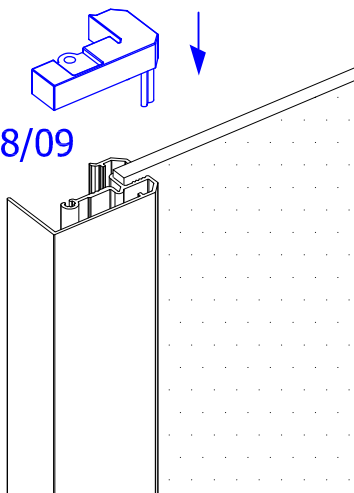

1e

51606/07

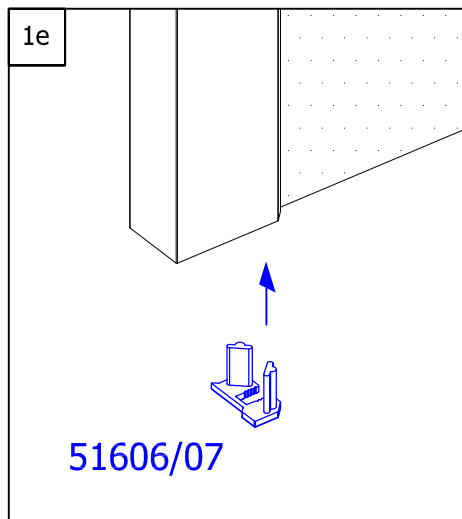

2.

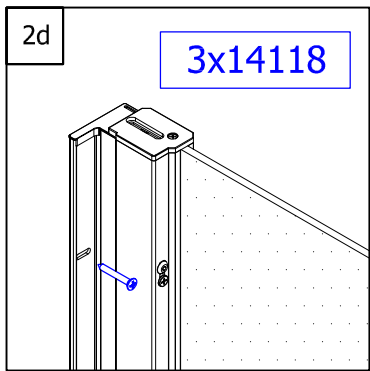
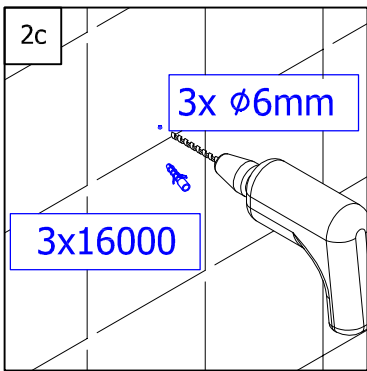
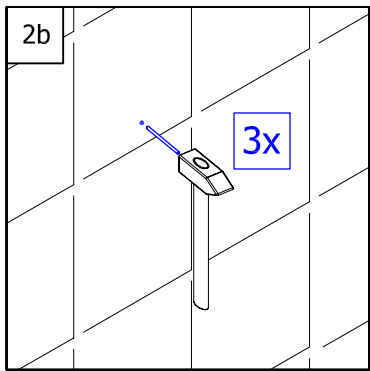
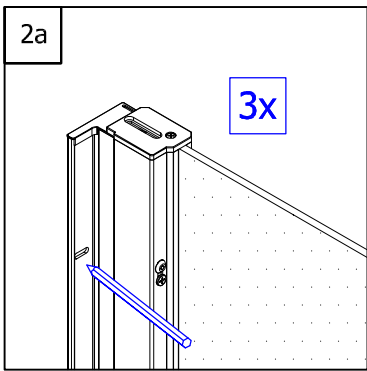
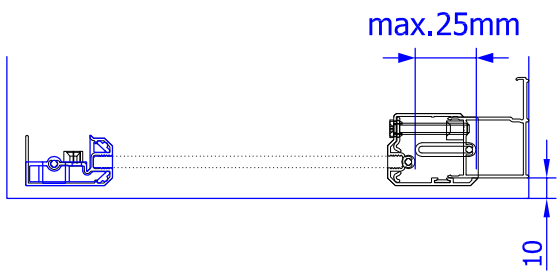
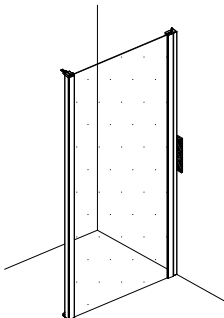

3a

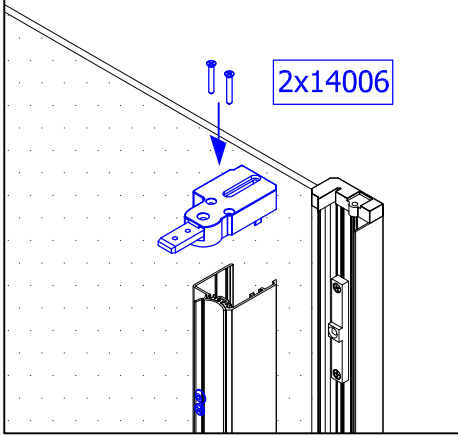

3b

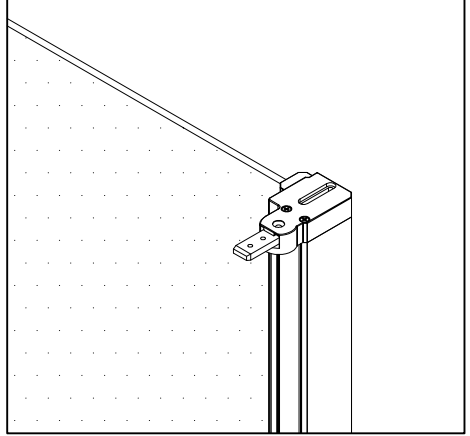

3.

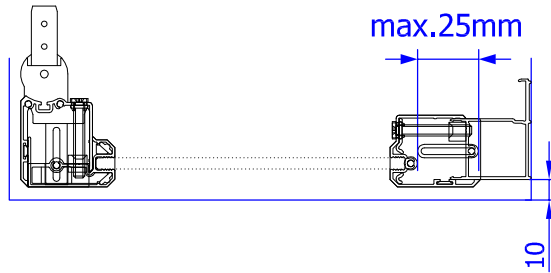
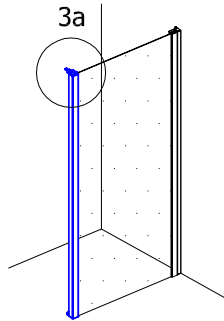

4a

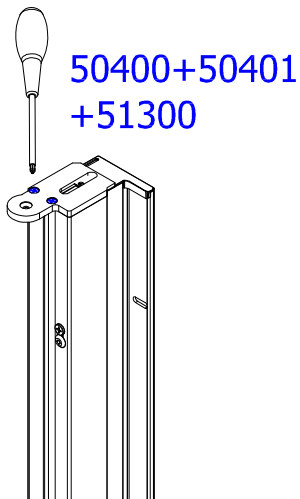

4b

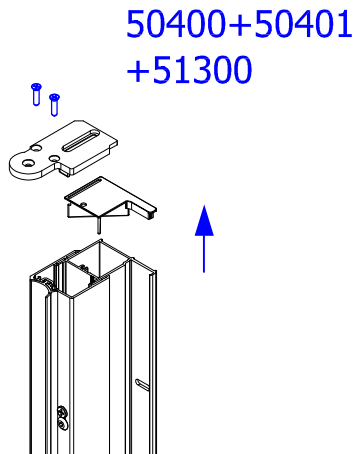

4c

51610/11+54408/09
+2x14006

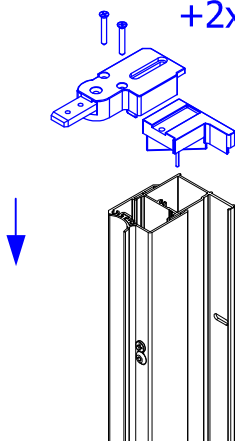

54402/03+51798/99



4d

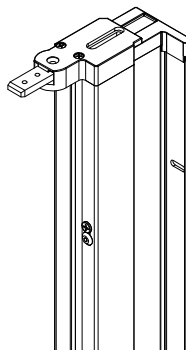

4.

5.

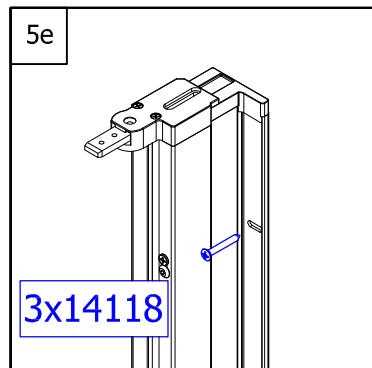
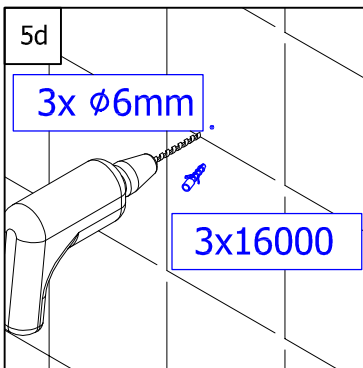
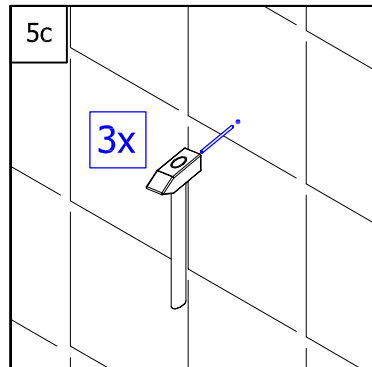
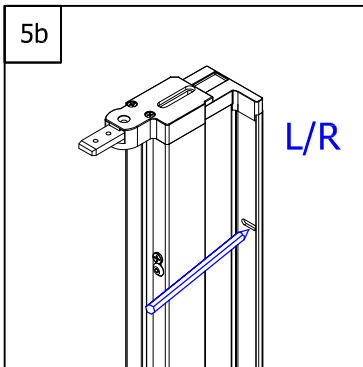
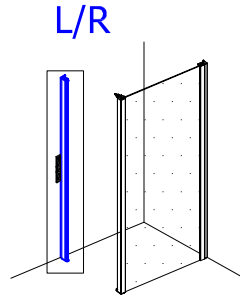
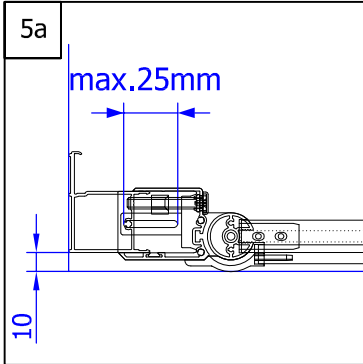

6.

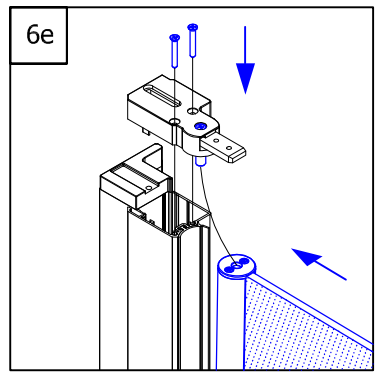
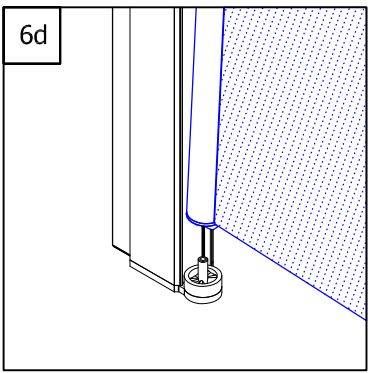
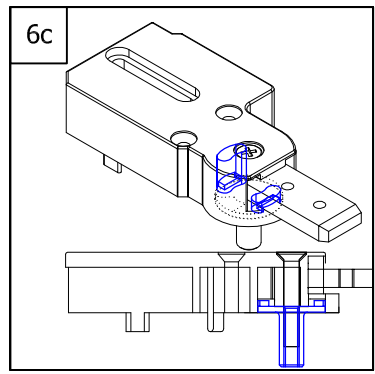
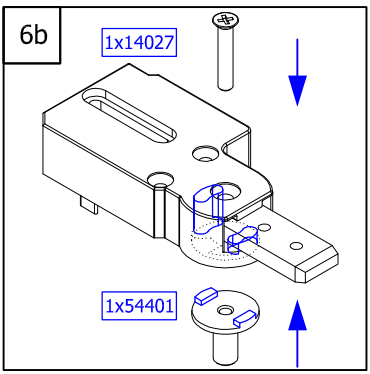
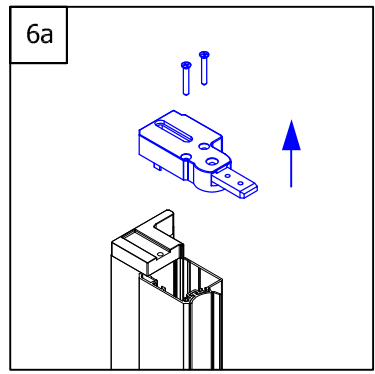
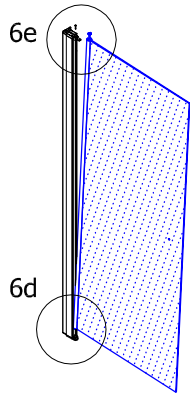

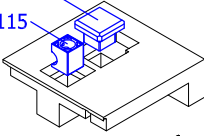
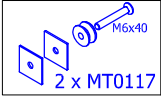

7a

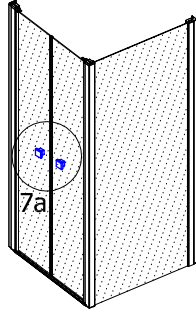
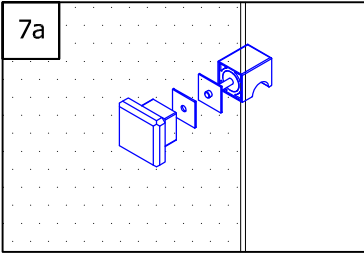

7b

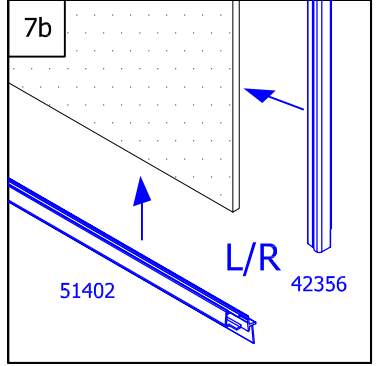

7c

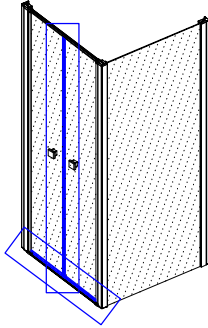
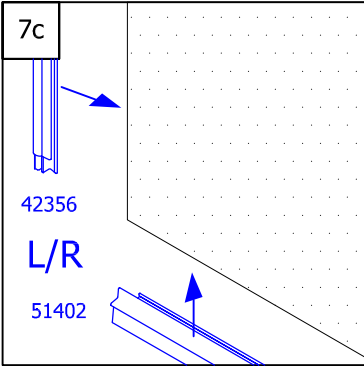

7d

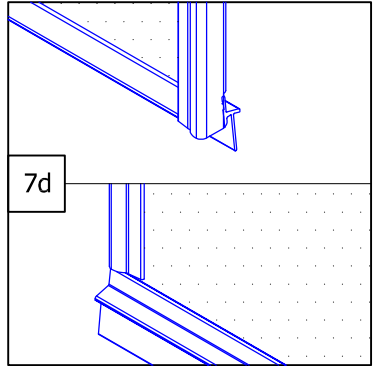

7e

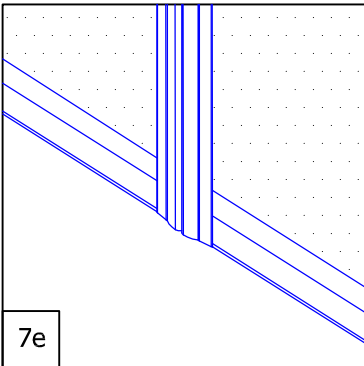

7.

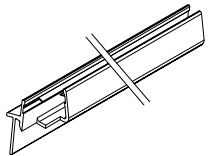
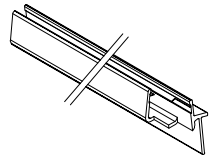

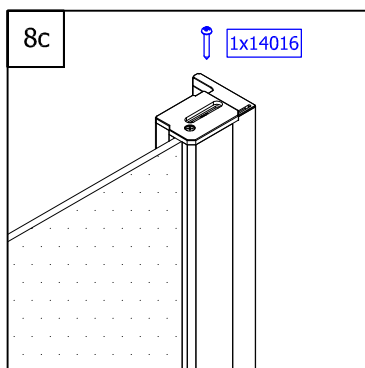
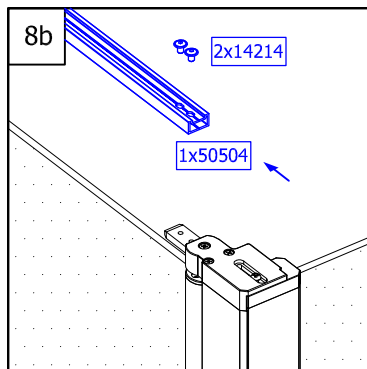
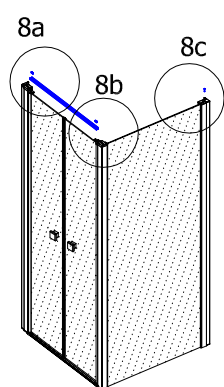
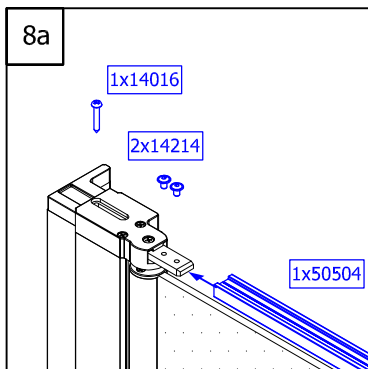
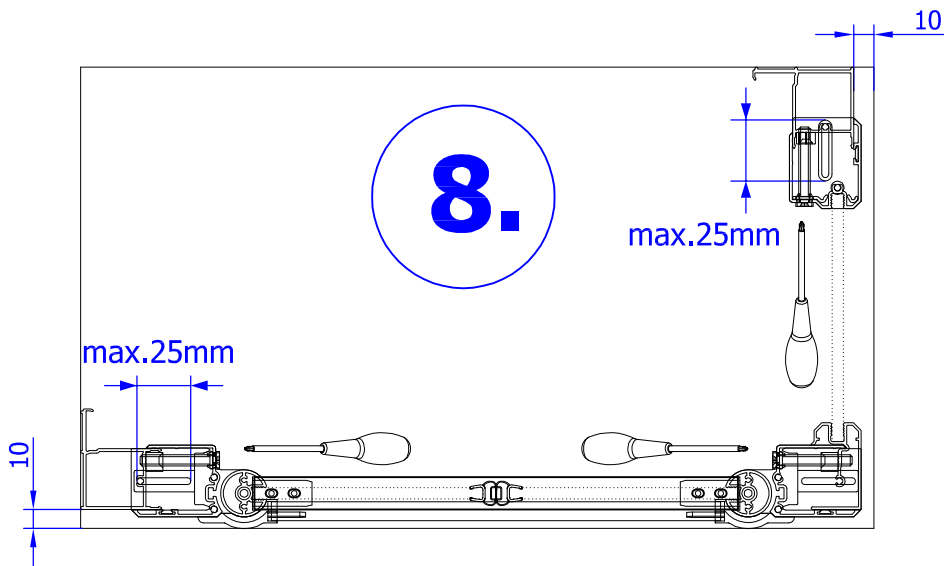

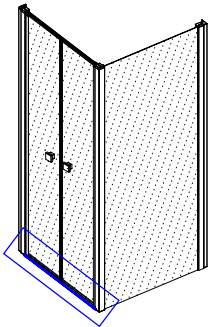
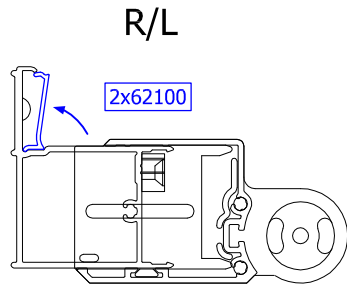
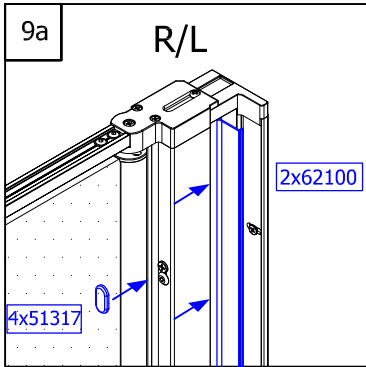

9.

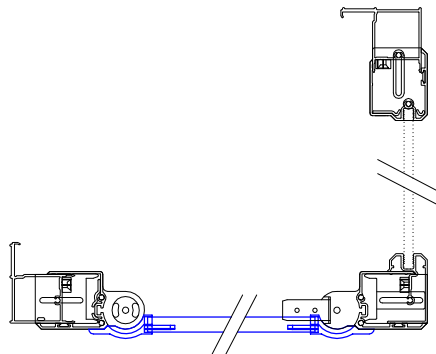
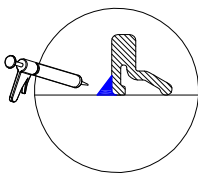
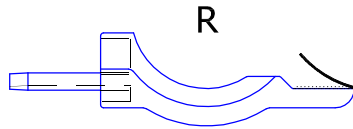
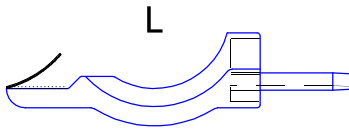
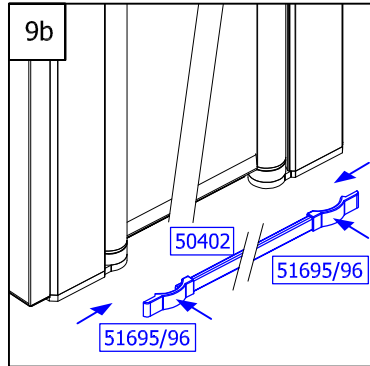

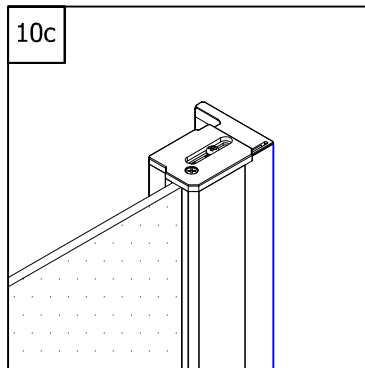
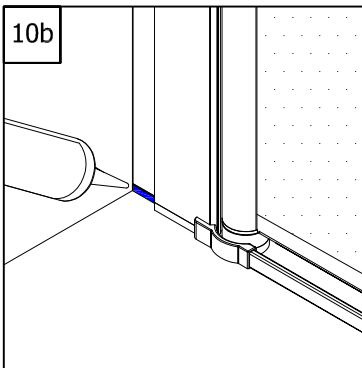
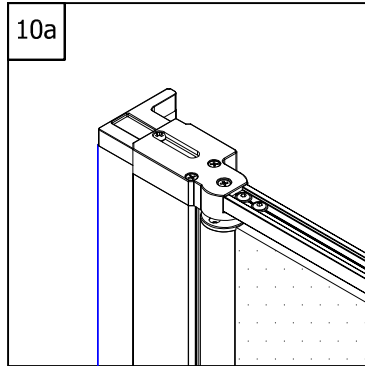
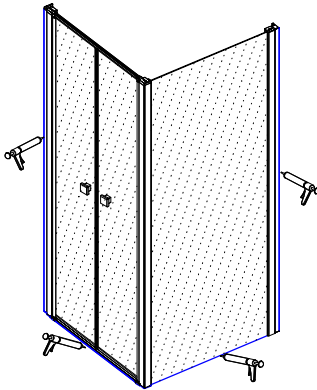

Achtung! Nur Sanitär-Silikon - bakterizid und fungizid eingestellt verwenden.

Caution! Use only bactericidal and fungicide sanitary silicone.

Attention! N'utiliser que du silicone sanitaire bactéricide et fongicide.

Pozor! Používejte pouze baktericidní a fungicidní sanitární silikon.

Uwaga! Stosować tylko silikon sanitarny - bakterio- i grzybobójczy.

Pozor! Užívajte pouze baktericidný a fungicidný sanitárny silikón.

Figyelem! Csak szaniter sziloplaszt - baktérium és gombamentes - használata megengedett.

Cuidado! Utilizar solamente silicona sanitaria bactericida y fungicida.

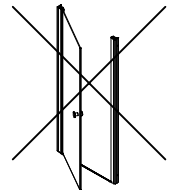
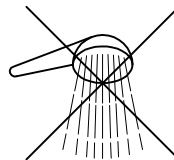

10.

SL2+SLT2

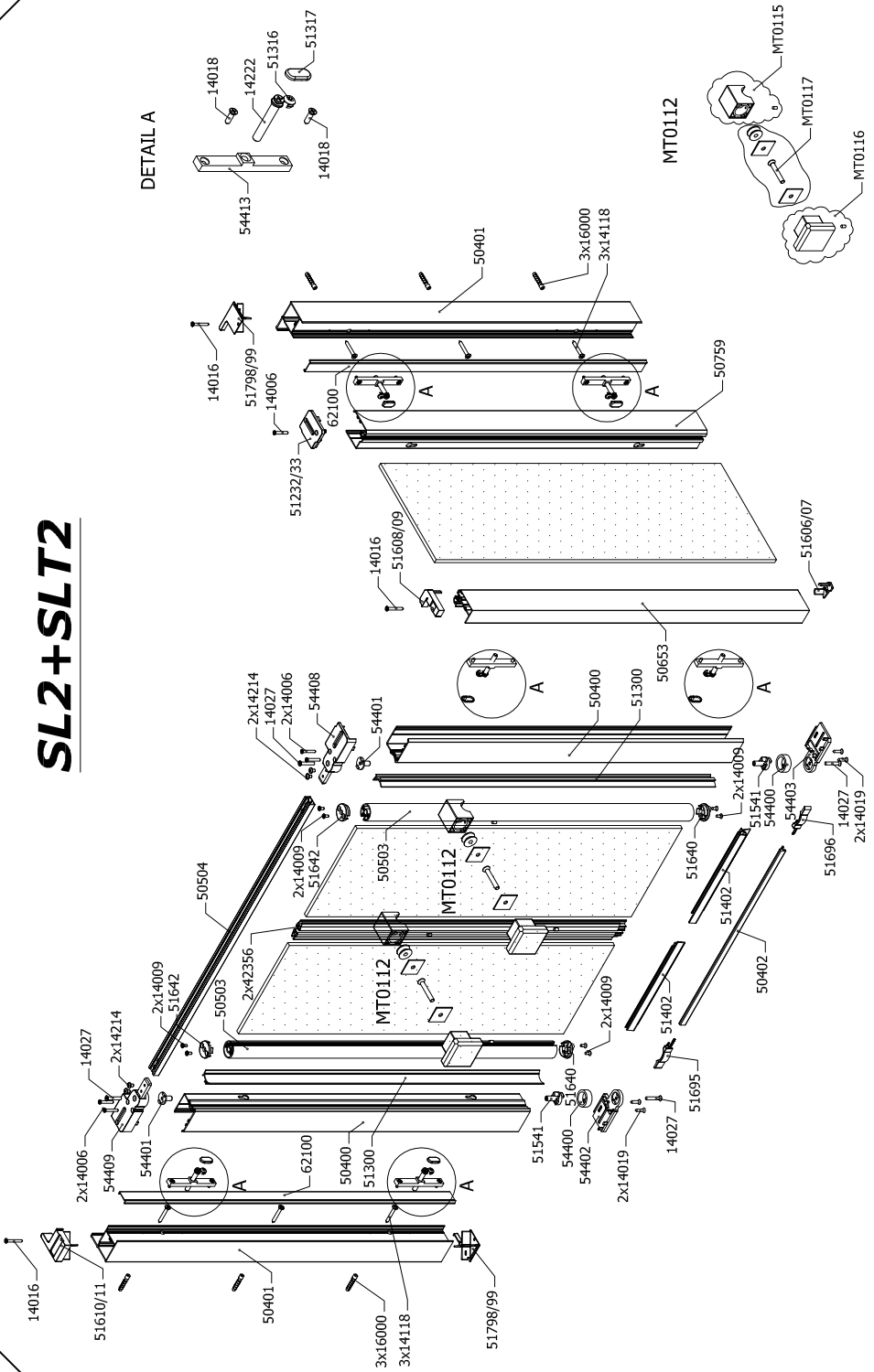

QUALITY CONTROL:

- D** Falls Sie Reklamationen haben, oder Sie unzufrieden mit Ihrem RONAL Produkt sind, beschreiben Sie bitte unten auf diesem Blatt den Produktfehler und übergeben Sie dieses Dokument Ihrem Verkäufer, oder direkt der Firma RONAL. Diese Information hilft uns, die Qualität von unseren Produkten weiter zu verbessern.
- GB** In case of a complaint or Your dissatisfaction with the RONAL product, please describe the defect below and pass this document to Your vendor, or directly to the RONAL company. This information will help us in the next increase of the quality of our products.
- F** En cas de réclamations lors de la livraison ou l'installation de votre paroi de douche RONAL, veuillez, s'il vous plaît, noter vos remarques au bas de la feuille et transmettre les informations à votre revendeur. Elles nous permettrons d'améliorer notre qualité et par la même notre service.
- CZ** V případě reklamace, či Vaší nespokojenosti s výrobkem RONAL popište prosím ve spodní části tohoto listu závadu a dokument prosím odevzdejte Vašemu prodejci nebo přímo firmě RONAL. Tato informace nám pomůže v dalším zvýšení kvality našich výrobků.
- PL** Reklamacje , oraz inne niezgoności związane z produktem RONAL prosimy przekazywać sprzedawcy na załącznym druku.
- SK** V prípade reklamácie, alebo Vašej nespokojnosti s výrobkom RONAL, popište prosím v spodnej časti tohto listu závalu a dokument prosím odovzdajte Vašemu prodejci, alebo priamo firme RONAL. Táto informácia nám pomôže v ďalšom zvýšení kvality našich výrobkov.
- H** Abban az esetben ha reklamációja vagy panasza van az Ön által vásárolt RONAL termékkel, úgy azt írja meg a lap alján található helyre és adja át a kereskedőjének, vagy küldje el közvetlenül a RONAL cégnek! Ez az információ segít nekünk termékeink minőségének javításában.
- E** En caso de reclamaciones ó si no está satisfecho con su producto RONAL, por favor describan en la parte inferior de esta hoja el fallo del producto y entreguen este documento a su vendedor ó directamente a la empresa RONAL. Esta información nos ayuda a seguir mejorando la calidad de nuestros productos.
- RO** În cazul în care aveți reclamații sau nemulțumiri legate de produsele RONAL, vă rugăm să descrieți defectiunea și să transmiteți acest document vânzătorului sau direct firmei RONAL. Această informație ne ajută să îmbunătățim în continuare calitatea produselor noastre.

.....

.....

.....

.....

.....

.....

