



Ersatzteilliste
Spare Parts List

2015-12

PM-46 SBC

(D, GB)

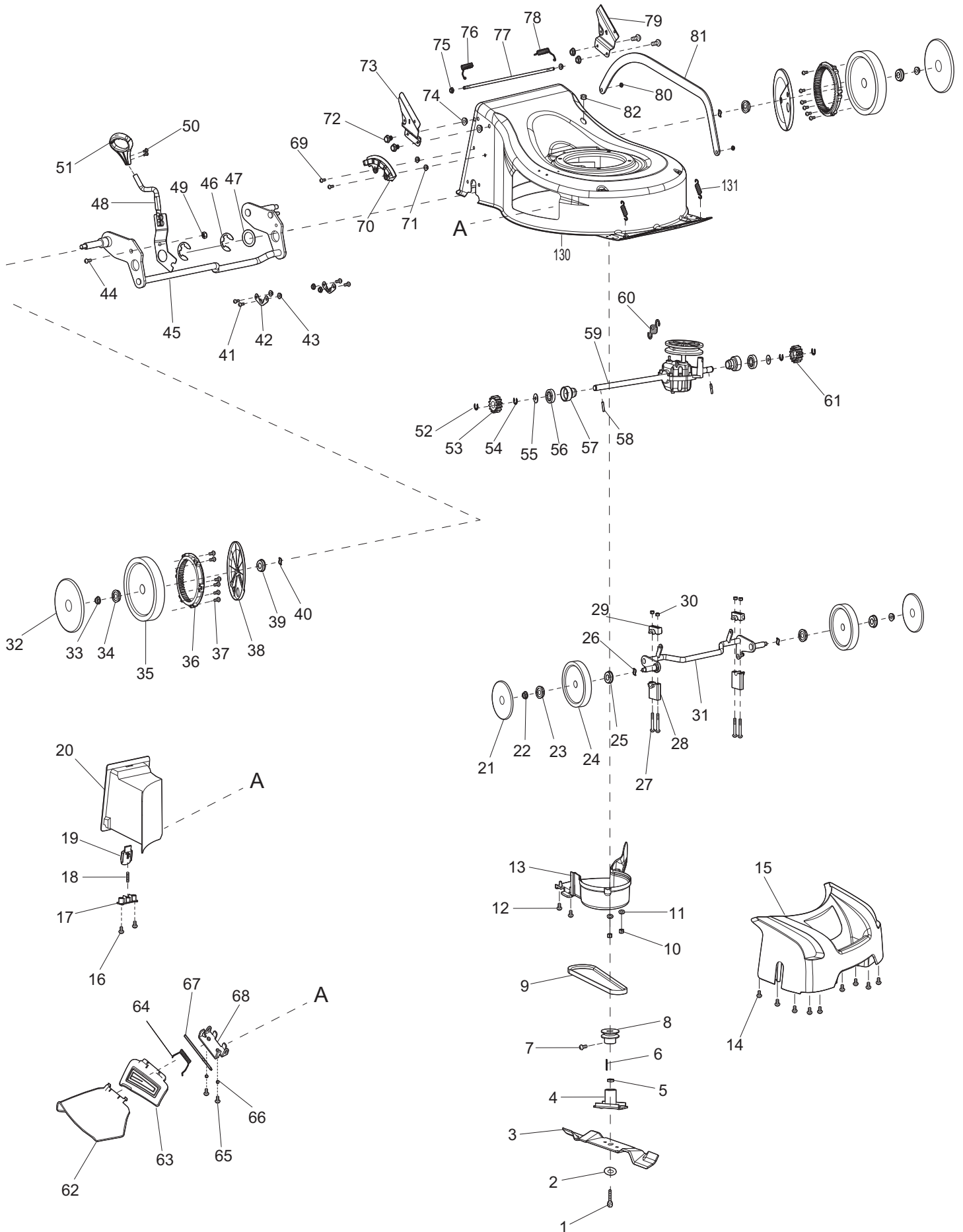

Seite / Page	Pos.	PM-46 SBC	Teil-Nr. Part No.	Hinweise Notes	Bezeichnung	Spezifikation Specification	Description
1	1	1	671006062		MESSERSCHRAUBE	3/8", L=40mm	BLADE TIGHTEN SCREW
1	2	1	671010730		SCHEIBE	Φ44.5/10.2x2.5	LID SHAPE WASHER
1	3	1	671014610		MESSER	460X55X4mm	BLADE
1	4	1	671002448		MESSERHALTER		BLADE SUPPORT
1	5	1	671002092		BUCHSE		BUSH
1	6	1	671090077		PASSFEDER	4.7x4x4.7	FLAT KEY
1	7	1	671030050		6KT-SCHRAUBE	M6x8	HEXAGON HEAD BOLT
1	8	1	671004002		RIEMENSCHLEIBE	45	PULLEY
1	9	1	671012720		KEILRIEMEN	Li=762mm	V-BELT
1	10	2	671005008		6KT-MUTTER	M8	HEXAGONAL LOCKING NUT
1	11	2	671007007		SCHEIBE	φ8	WASHER
1	12	2	671001037		SCHRAUBE SELBSTSCHNEIDEND	5x16	SELF-TAPPING SCREW
1	13	1	671580010		RIEMENABDECKUNG		BELT PROTECTION COVER
1	14	9	671001037		SCHRAUBE SELBSTSCHNEIDEND	5x16	SELF-TAPPING SCREW
1	15	1	671536001		FRONTTEIL	18"	FRONT COVER
1	16	2	671107301		SCHRAUBE SELBSTSCHNEIDEND	ST4x16	SELF-TAPPING SCREW
1	17	1	671317001		DRUCKPLATTE		PRESSURE PLATE
1	18	1	671011005		FEDER	φ8,0xφ0,9x31mm	SPRING
1	19	1	671316004		VERRIEGELUNGSKNOPF	20"	LOCKING BUTTON
1	20	1	671326001		MULCHKEIL		MULCHING KIT
1	21	2	671105103		RADKAPPE	8"	WHEEL COVER
1	22	2	671005028		6KT-MUTTER	M8	HEXAGONAL LOCKING NUT
1	23	2	671040160		LAGER		BEARING
1	24	2	671204301		RAD KPL.	8"	WHEEL ASS'Y
1	25	2	671040160		LAGER		BEARING
1	26	2	671007062		WELLENSCHLEIBE	φ12xφ18x0.5	WAVE WASHER
1	27	4	671006119		SCHRAUBE	M6x60	BOLT
1	28	2	671376001		LAGERSCHALE		BEARING SHELL
1	29	2	671376002		LAGERSCHALE		BEARING SHELL
1	30	4	671005005		6KT-MUTTER	M6	LOCKING NUT
1	31	1	671001374		VORDERACHSE	18"	FRONT WHEEL AXLE
1	32	2	671010530		RADKAPPE	11"	WHEEL COVER
1	33	2	671005028		6KT-MUTTER	M8	HEXAGONAL LOCKING NUT
1	34	2	671040160		LAGER		BEARING
1	35	2	671020440		RAD KPL.	11"	WHEEL ASS'Y
1	36	2	671295001		ZAHNRAD	11"	GEAR WHEEL
1	37	12	671107301		SCHRAUBE SELBSTSCHNEIDEND	ST4x16	SELF-TAPPING SCREW
1	38	2	671087001		STAUBSCHUTZABDECKUNG		DUST COVER
1	39	2	671040160		LAGER		BEARING
1	40	2	671007062		WELLENSCHLEIBE	φ12xφ18x0.5	WAVE WASHER
1	41	4	671002019		SCHRAUBE	M6x12	TRIGGER BOLT
1	42	2	671001244		FIXIERUNG		RING OF AXLE FIXING
1	43	4	671005024		6KT-MUTTER	M6	HEXAGONAL LOCKING NUT
1	44	1	671002030		SCHRAUBE	M6x14	TRIGGER BOLT
1	45	1	671001372		HINTERRADACHSE		REAR WHEEL AXLE
1	46	2	671009003		SICHERUNGSSCHLEIBE	φ19x1.5	SAFETY WASHER
1	47	1	671001076		FEDERSCHLEIBE	φ35xφ22.5x1.5	SPRING WASHER
1	48	1	DA00000904		HANDGRIFF KPL.		HANDLE ASS'Y
1	49	1	671005005		6KT-MUTTER	M6	LOCKING NUT
1	50	2	671003033		SCHRAUBE	M5x8	SCREW
1	51	1	671010590		GRIFF		GRIP
1	52	2	671090020		SICHERUNGSSCHLEIBE		SAFETY WASHER
1	53	1	671003002		ZAHNRAD, RECHTS		RIGHT GEAR
1	54	2	671090020		SICHERUNGSSCHLEIBE		SAFETY WASHER
1	55	2	671007051		FLACHSCHLEIBE	φ12.8xφ20x0.8	FLAT WASHER
1	56	2	671004023		LAGER		BEARING
1	57	2	671002031		LAGERGEHÄUSE		BEARING HOUSING
1	58	2	671090001		ZYLINDERSTIFT	Φ5x21.5	CYLINDRICAL PIN
1	59	1	671501028		ANTRIEB	18"	GEAR BOX
1	60	1	671011174		DREHFEDER		SPRING OF GEAR BOX
1	61	1	671003001		ZAHNRAD, LINKS		GEAR WHEEL, LEFT
1	62	1	671381001		SCHUTZHAUBE SEITENAUSWURF		PROTECTION COVER
1	63	1	671380001		MULCHABDECKUNG		SIDE DISCHARGE COVER
1	64	1	671111300		DREHFEDER	φ3.1	TORSION SPRING

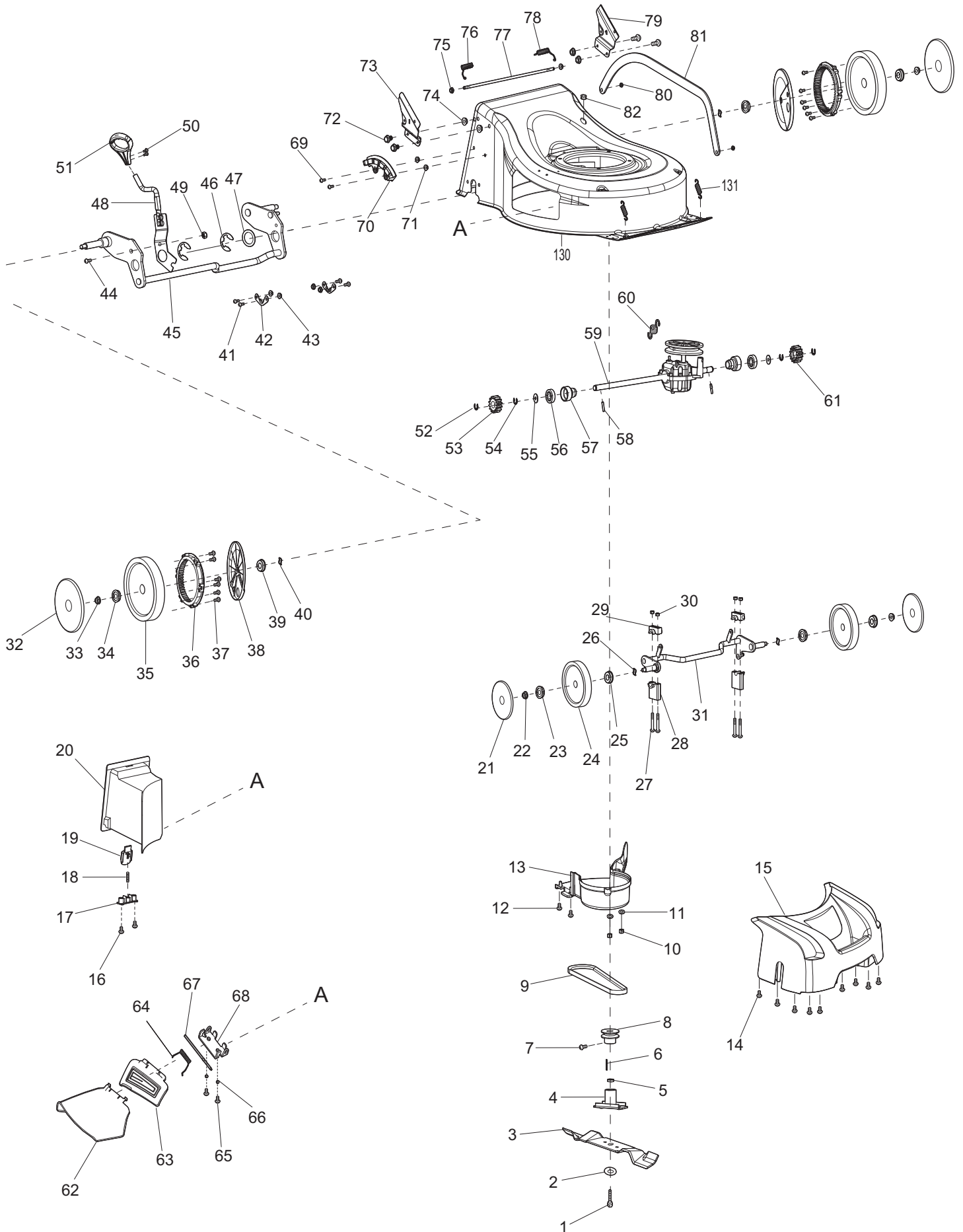

Seite / Page	Pos.	PM-46 SBC	Teil-Nr. Part No.	Hinweise Notes	Bezeichnung	Spezifikation Specification	Description
1	65	2	671201501		SCHRAUBE	M5x10	TRIGGER BOLT
1	66	2	671080040		FEDERSCHEIBE		SPRING WASHER
1	67	1	671001019		ACHSE		AXLE
1	68	1	671021830		FIXIERBLECH		FIXED PLATE
1	69	2	671002019		SCHRAUBE	M6x12	TRIGGER BOLT
1	70	1	DA00000898		RASTPLATTE HÖHENVERSTELLUNG		HEIGHT ADJUSTMENT PLATE
1	71	2	671005024		6KT-MUTTER	M6	HEXAGONAL LOCKING NUT
1	72	4	671006064		6KT-SCHRAUBE	M8x6	HEXAGON HEAD BOLT
1	73	1	671001753		GRIFFANBINDUNG, RECHTS	18", DOLMAR	BRACKET HANDLE, RIGHT
1	74	4	671005028		6KT-MUTTER	M8	HEXAGONAL LOCKING NUT
1	75	2	671005024		6KT-MUTTER	M6	HEXAGONAL LOCKING NUT
1	76	1	671011113		DREHFEDER RECHTS		TORSION SPRING, RIGHT
1	77	1	671001366		STANGE GRASKLAPPE	φ6,18"	LONG POLE
1	78	1	671011114		DREHFEDER LINKS		TORSION SPRING, LEFT
1	79	1	671001752		GRIFFANBINDUNG, LINKS	18", DOLMAR	BRACKET HANDLE, LEFT
1	80	2	671005005		6KT-MUTTER	M6	LOCKING NUT
1	81	1	671001377		VERBINDUNGSSTANGE	18"	LINK ROD
1	82	1	671800104		GUMMITÜLLE		CORD PROTECTING SHEATH
1	130	1	671001749		DECK	18", DOLMAR	DECK
1	131	2	DA00000897		FEDER		FRONT WHEEL AXIS SPRING

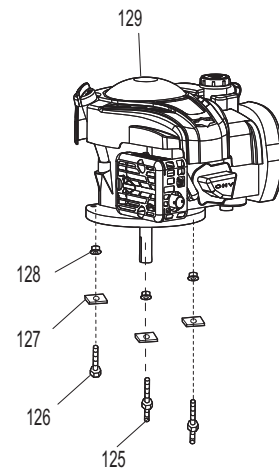
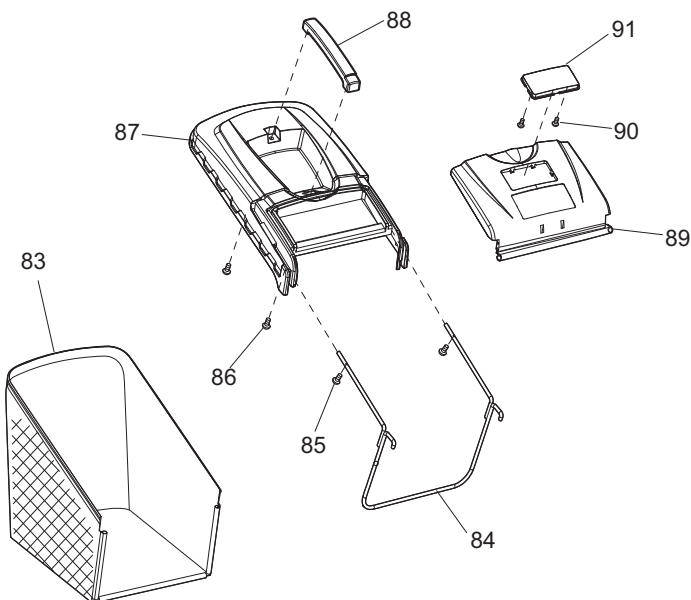
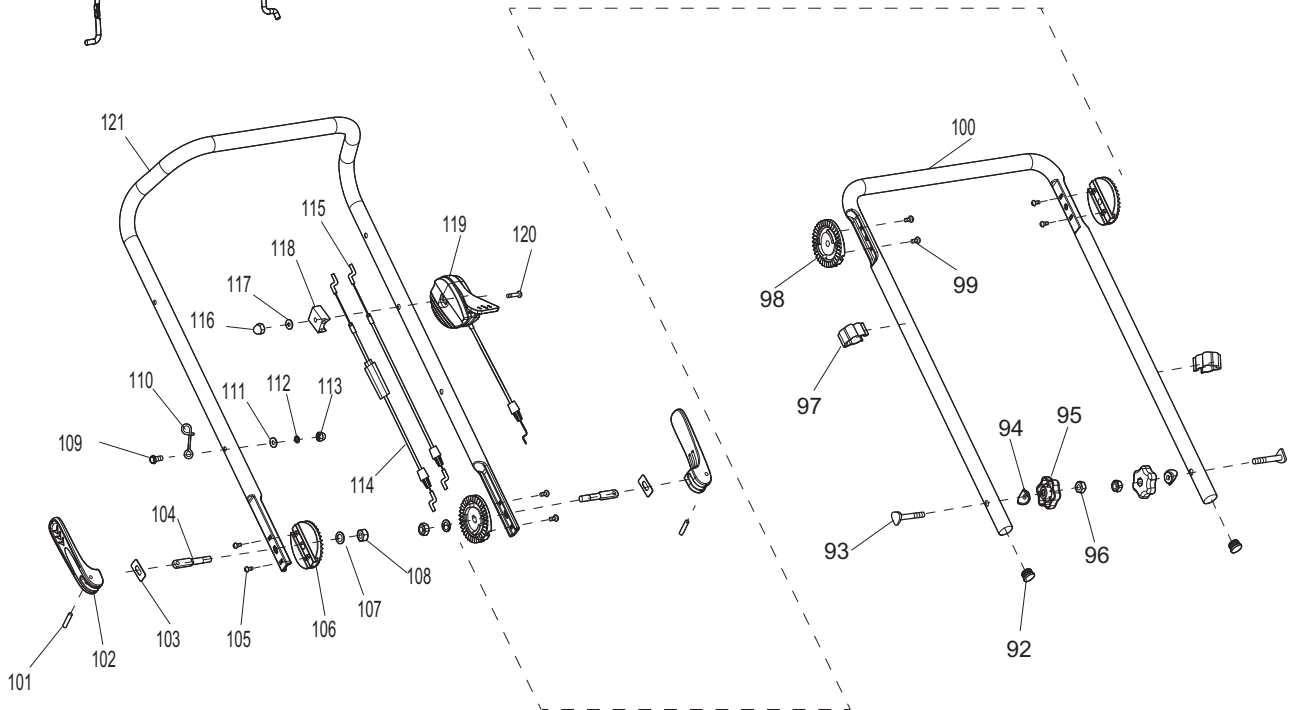
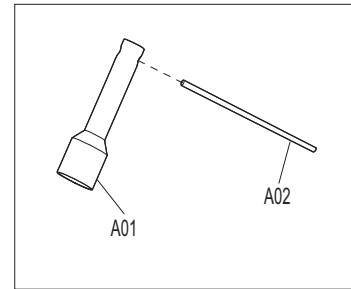
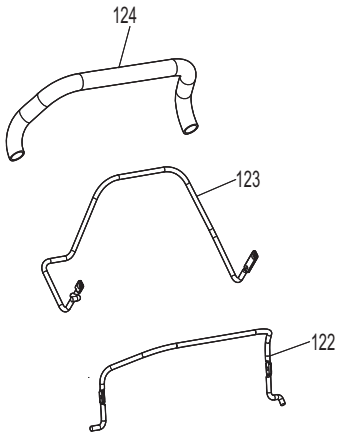

Seite / Page	Pos.	PM-46 SBC	Teil-Nr. Part No.	Hinweise Notes	Bezeichnung	Spezifikation Specification	Description
2	83	1	671013784		GRASFANGKORB	60L, DOLMAR LOGO	GRASS CATCHER
2	84	1	671001381		RAHMEN	18"/20"	GRASS CATCHER BRACKET
2	85	2	671001032		SCHRAUBE	4,2x18	BOLT
2	86	2	671001046		SCHRAUBE SELBSTSCHNEIDEND	8x19	SELF-TAPPING SCREW
2	87	1	671382001		KORB, OBERTEIL	60L	GRASS-BOX, UPPER
2	88	1	671384001		HANDGRIFF		GRASS CATCHER HANDLE
2	89	1	671004272		HECKKLAPPE KPL.		REAR FLAP ASS'Y
2	90	2	671010710		SCHRAUBE SELBSTSCHNEIDEND	ST4x12	SELF-TAPPING SCREW
2	91	1	671385001		SICHTFENSTER		TRANSPARENT WINDOW
2	92	2	DA00000900		ROHRSTOPFEN		TUBE PLUG
2	93	2	671006004		FLACHKOPFSCHRAUBE	M8x52	FLAT HEAD BOLT
2	94	2	671001085		SCHEIBE		WASHER
2	95	2	671365005		STERNGRIFFMUTTER		STAR KNOB
2	96	2	671005023		6KT-MUTTER	M8	HEXAGONAL NUT
2	97	2	671611001		BOWDENZUGHALTER		BOWDEN CABLE CLAMP
2	98	2	671055001		EINSTELLRING, UNTEN		LOWER ADJUSTING TOOTH RING
2	99	4	DA00000860		SCHRAUBE SELBSTSCHNEIDEND	ST3X10	SELF-TAPPING SCREW
2	100	1	671001804		UNTERHOLM		LOWER HANDLE
2	101	2	671090048		ZYLINDERSTIFT	5x20	CYLINDRICAL PIN
2	102	2	671364005		VERSTELLGRIFF		LOCKING HANDLE
2	103	2	671001119		DRUCKPLATTE		PRESSURE PLATE
2	104	2	671001301		SCHRAUBE	M8x69	BOLT
2	105	4	DA00000860		SCHRAUBE SELBSTSCHNEIDEND	ST3X10	SELF-TAPPING SCREW
2	106	2	671054001		EINSTELLRING, OBEN		UPPER ADJUSTING TOOTH RING
2	107	2	671011890		FLACHSCHEIBE	φ16xφ8x0,8	FLAT WASHER
2	108	2	671005008		6KT-MUTTER	M8	HEXAGONAL LOCKING NUT
2	109	1	671006077		SCHRAUBE	M6x35	BOLT
2	110	1	671001647		HAKEN		CABLE HOOK
2	111	1	671007008		SCHEIBE	φ16xφ8x0,8	WASHER
2	112	1	DA00000864		FEDERSCHEIBE	M6	SPRING WASHER
2	113	1	671050160		6KT-MUTTER	M6	HEXAGONAL LOCKING NUT
2	114	1	671001258		BOWDENZUG (MOTORBREMSE)	960mm	CONTROL CABLE (MOTOR BRAKE)
2	115	1	671001222		BOWDENZUG (RADANTRIEB)		CONTROL CABLE (WHEEL DRIVE)
2	116	1	671050160		6KT-MUTTER	M6	HEXAGONAL LOCKING NUT
2	117	1	671007008		SCHEIBE	φ16xφ8x0,8	WASHER
2	118	1	671336001		KABELHALTER		CABLE HOLDER
2	119	1	671013260		MOTORFERNBEDIENUNG INKL. BOWDENZUG		THROTTLE HANDLE ASS'Y
2	120	1	671006036		SCHRAUBE	M6x50	BOLT
2	121	1	671017970		OBERHOLM		UPPER HANDLE
2	122	1	671017580		HEBEL, MOTORBREMSE		LEVER, MOTOR BRAKE
2	123	1	671001732		HEBEL, ANTRIEB	18"	LEVER, DRIVING
2	124	1	671001029		GRIFFUMHÜLLUNG		HANDLE SHEATH
2	125	2	671003044		SPEZIALSCHRAUBE	M8x17x35	SPECIAL SCREW
2	126	1	671006025		6KT-SCHRAUBE	M8x35	HEXAGON BOLT
2	127	3	671002106		4KT-SCHEIBE	φ10	SQUARE GASKET
2	128	3	671005028		6KT-MUTTER	M8	HEXAGONAL LOCKING NUT
2	A01	1	671001612		STECKSCHLÜSSEL	16mm	BOX SPANNER
2	A02	1	671001079		SPANNSTANGE	Φ8x110mm	SPANNER POLE

- 1** DECK, RÄDER, MESSER
DECK, WHEELS, BLADE
- 2** FÜHRUNGSHOLM, GRASFANGKORB
GUIDE TUBE, GRAS CATCHER

	Zeichenerklärung	Key to symbols
=> 1999999 2000000 => 2003.04 => TI 2003/07 Acc. = { m Corr.	Produktion bis Serien-Nr. Neues Teil ab Serien-Nr. Neues Teil ab Jahr / Monat Siehe Technische Information Jahr / Nr. Zubehör (nicht im Lieferumfang) Keine Serienausführung, jedoch verwendbar Beinhaltet Positions-Nr. Meterware Druckfehlerberichtigung	Production to serial number New part from serial number New part from Year / Month See Technical Information Year / No. Accessories (not included in the delivery inventory) No standard execution, may be used Contains item number Sold by the meter Error correction
	Änderungen vorbehalten	Specifications subject to change without notice