



BOSCH

Akku-Winkelschleifer

GWS 18V-180 PC | 3 601 JH6 E04

Inhaltsverzeichnis

Abbildung - Typ.....2

Abbildung - Typ - E

3 601 JH6 E04
Stand } 22-09-06
Issue } **Fig./Abb. 1**

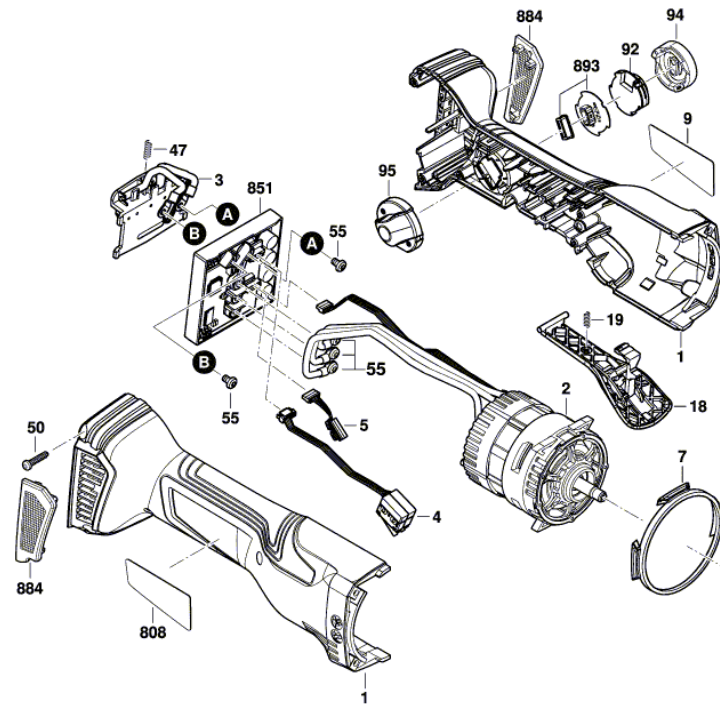

Änderungen vorbehalten
Modifications reserved
Modifications réservées
Salvo modificaciones

● = Zahnspiel 0,08 - 0,25mm mit Pos. 35 eingestellt
Tooth clearance 0.05 - 0.20mm adjusted with Pos. 35

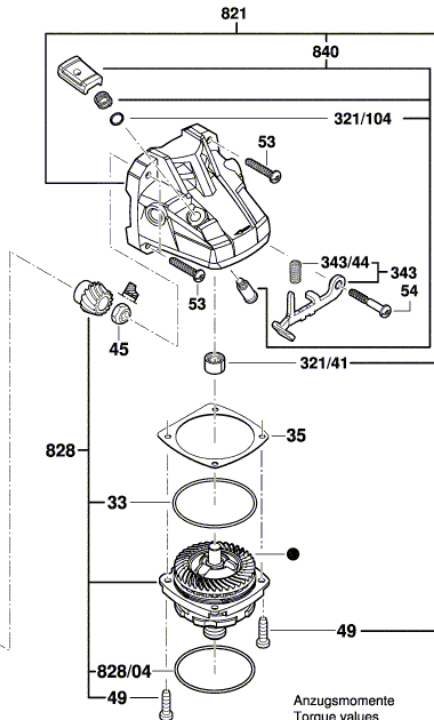

Anzugsmomente
Torque values
Couple de serrage
Pares de apriete
Pos. 45 = 8,0 - 12 Nm
Pos. 49 = 2,6 - 3,5 Nm
Pos. 50 = 0,8 - 1,0 Nm
Pos. 53 = 1,5 - 1,8 Nm
Pos. 54 = 1,5 - 1,8 Nm

Abbildung - Typ - E

3 601 JH6 E04
Stand } 22-09-06 **Fig./Abb. 2**
Issue }

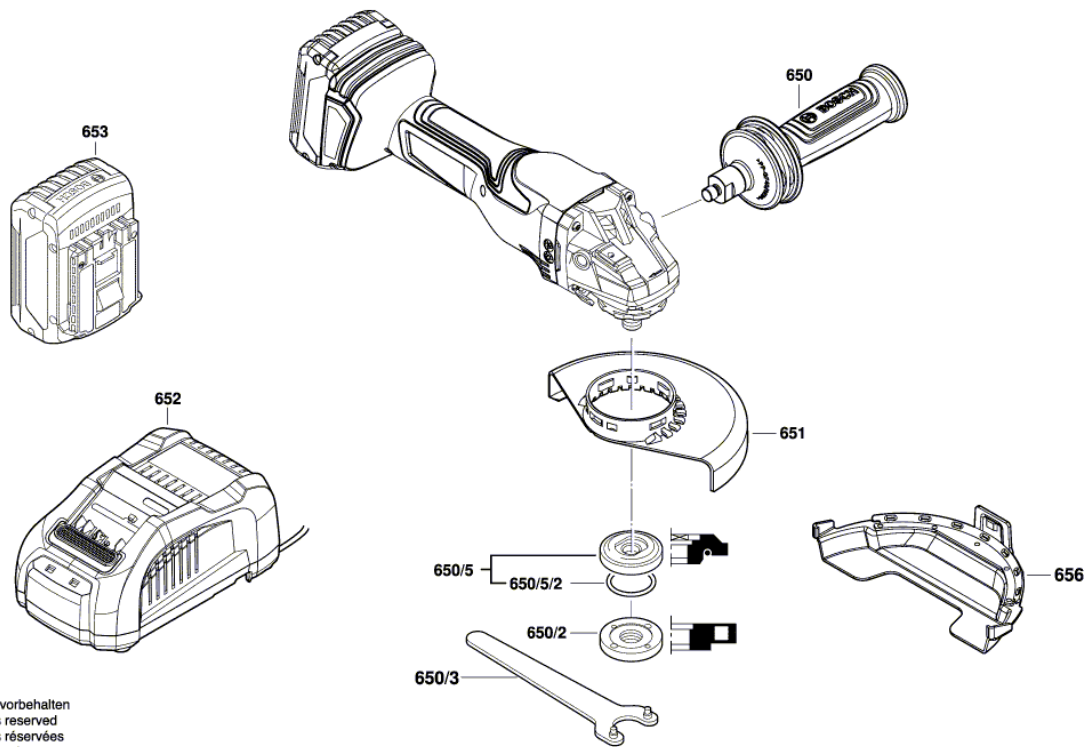

Änderungen vorbehalten
Modifications reserved
Modifications réservées
Salvo modificaciones