







Automatická umyvadlová baterie SLU 17B, 17SB, 27B, 27SB Automatická umývadlová batéria SLU 17B, 17SB, 27B, 27SB

Standartní funkce, Štandardná funkcia

<p>1.</p> 	<p>2.</p> 	<p>3.</p> 	<p>4.</p> 	<p>Regulace teploty Regulácia teploty</p> 
	<p>automatické vypnutí 5 min automatické vypnutie 5 min</p>	<p>nastavitelný interval vyp. vody nastaviteľný interval vyp. vody</p>		

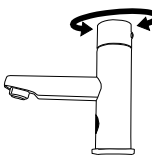
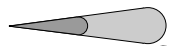
Vlastnosti

<p>0 0,3 m MIN MAX</p>  <p>cm AUTOMATICKY</p> <p>1. AUTOMATICKÉ NASTAVENÍ 2. NASTAVITELNÉ* 1. AUTOMATICKÉ NASTAVENIE 2. NASTAVITELNÉ*</p> <p>snímaná zóna 0,0 - 0,3 m</p>	<p>0,25 - 7,75 sec</p>  <p>1. AUTOMATICKY 0,25 sec. 2. NASTAVITELNÉ* 2. NASTAVITELNÉ*</p> <p>prodleva vyp. vody 0,25 - 7,75 sec oneskorenie vyp. vody 0,25 - 7,75 sec</p>	 <p>OFF/ON</p> <p>* pro další informace čtěte návod na SLD 03 * pre ďalšie informácie preštudujte návod na SLD 03</p> <p>zmáčkní OFF/ON stlačí OFF/ON</p>
---	--	--

**STANDARD ↔ START/STOP přepnutí
ŠTANDARD ↔ ŠTART/STOP prepnutie**

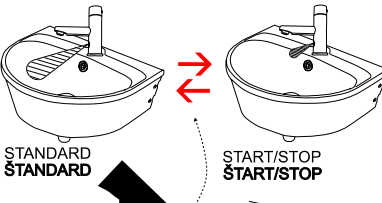







STANDARD
ŠTANDARD

START/STOP
ŠTART/STOP

* ZMÁČKNÍ ... max 5 sek. ... ZMÁČKNÍ
* STLAČ ... max 5 sek. ... STLAČ

START/STOP funkce, ŠTART/STOP funkcia

<p>1.</p> 	<p>2.</p>  <p>3 c 5 cm MIN MAX</p> <p>START ŠTART</p>	<p>3.</p> 	<p>4 a.</p>  <p>3 c 5 cm MIN MAX</p> <p>STOP</p>	<p>4 b.</p>  <p>10 - 310 sec</p>  <p>1. AUTOMATICKY 310 sek. 2. NASTAVITELNÉ* 2. NASTAVITELNÉ*</p> <p>STOP</p>
---	--	---	--	---

Doporučené příslušenství

SLA 09	Lithiová baterie 9V/1300 mAh, typ U9VL, životnost cca 2 roky při 4000 sepnutích měsíčně
SLD 03	Univerzální dálkové ovládání

Doporučené príslušenstvo

SLA 09	Lithiová batéria 9V/1300 mAh, typ U9VL, životnosť cca 2 roky pri 4000 zopnutiach mesačne
SLD 03	Univerzálne diaľkové ovládanie

Specifikace dodávky, Špecifikácia dodávky

SLU 17B - Obj. č. 03175

SLU 17SB - Obj. č. 33179

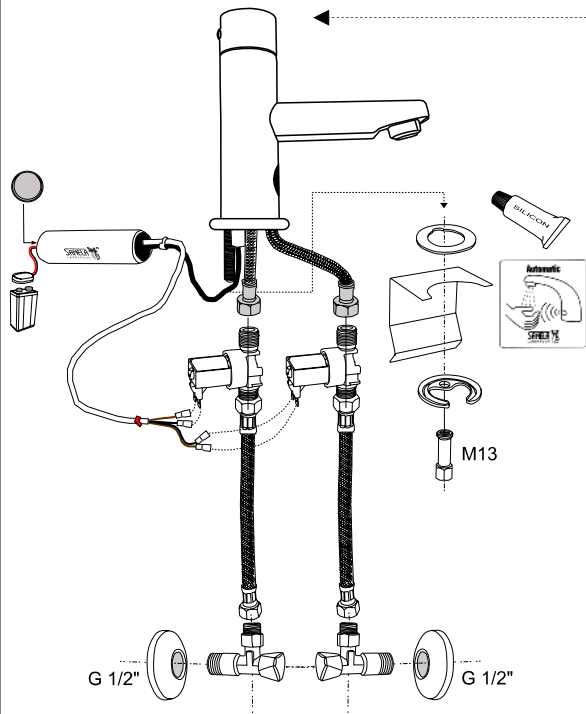

Specifikace dodávky, Špecifikácia dodávky

SLU 27B - Obj. č. 03275

SLU 27SB - Obj. č. 33279

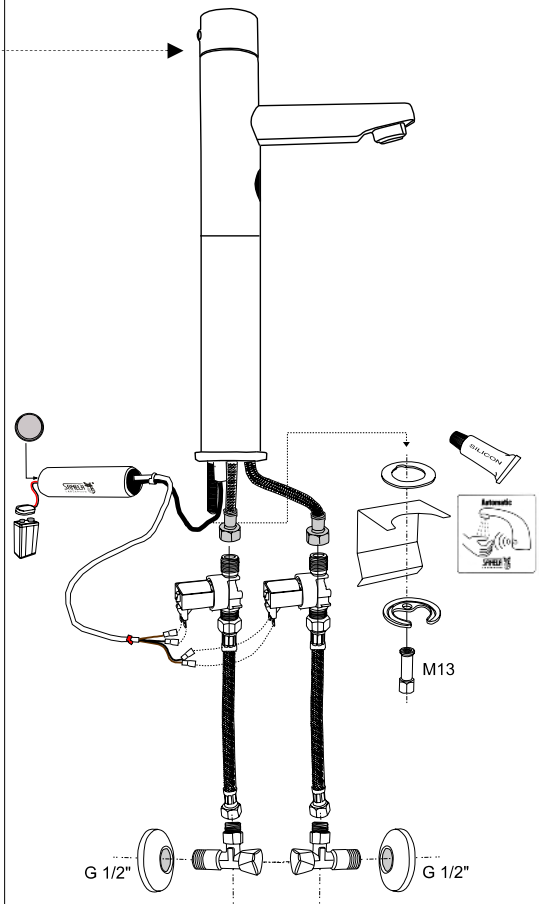

Instalace, Inštalácia

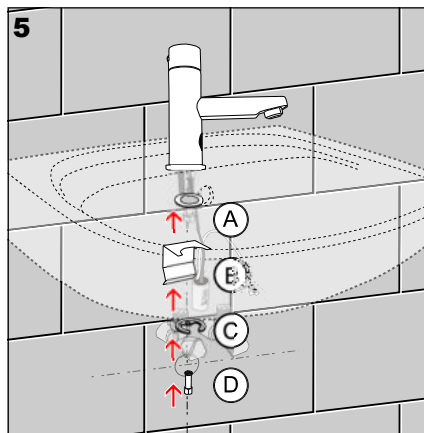
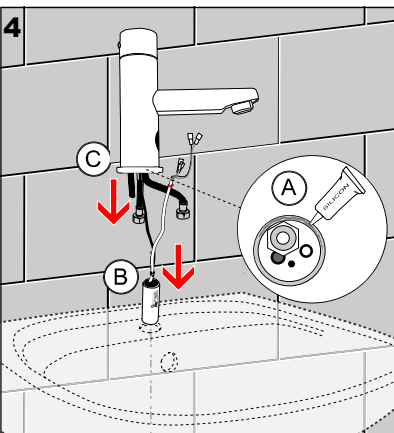
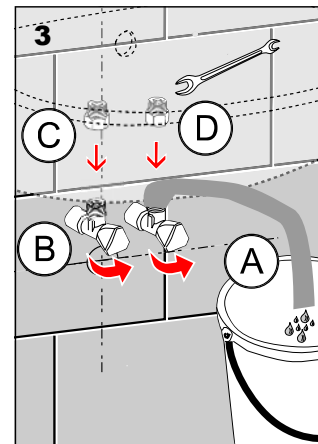
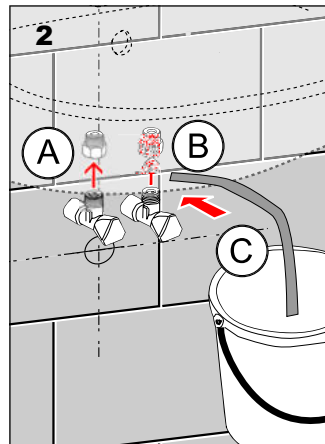
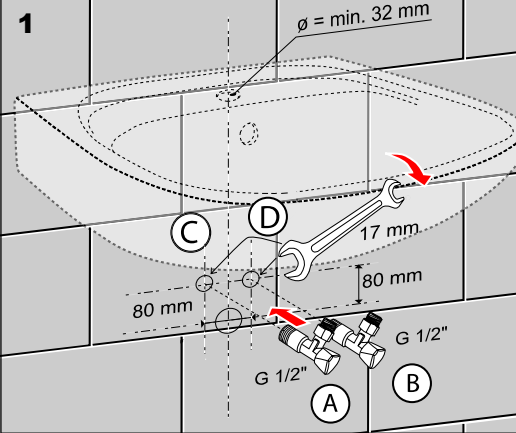

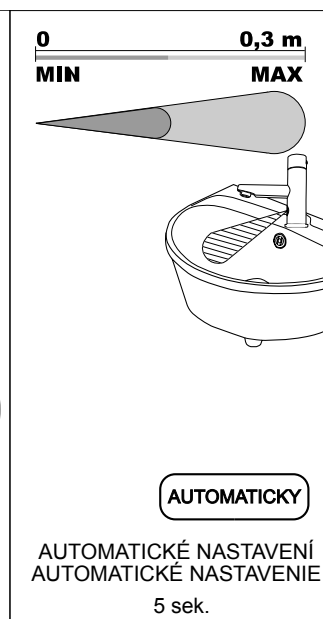
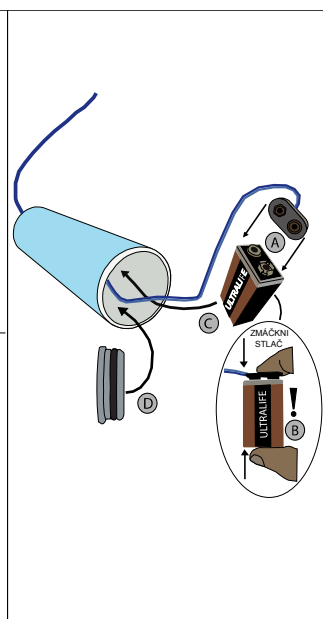
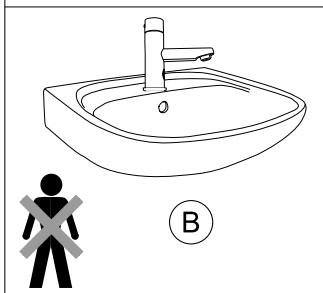
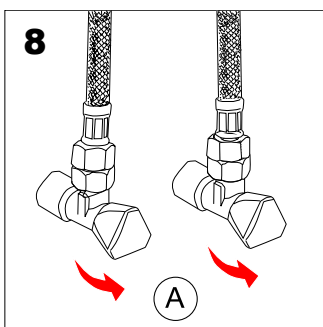
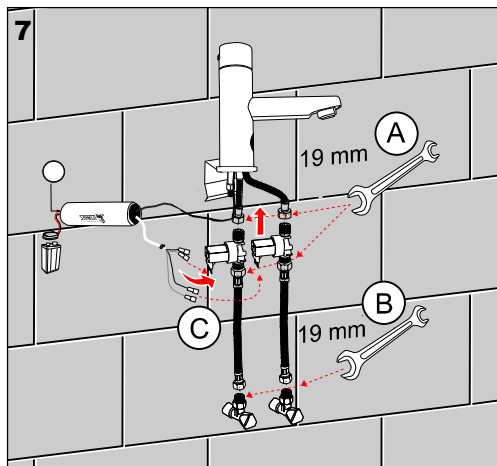
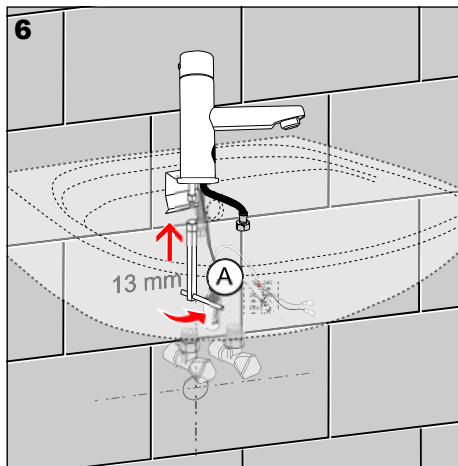

Servis

- vzhľadom k možnosti zanesení ventilu nečistotami z vody je doporučeno provést 1x ročně kontrolu sítka elektromagnetického ventilu, dotažení šroubových spojů a dosadacích ploch konektorů
- veškeré nerezové díly je možné čistit pouze vodou, mýdlem a měkkým hadrem, v žádném případě není možné použít agresivní a abrazivní čisticí prostředky
- po vybalení výrobku je nutné s obalem postupovat podle zákona o obalech
- výrobce ujišťuje, že na výrobek je vydáno prohlášení o shodě v souladu se zákonem č. 22/1997 Sb.

Servis

- vzhľadom k možnosti zanesenia ventilu nečistotami z vody sa doporučuje previesť 1x ročne kontrolu sítka elektromagnetického ventilu, dotiahnutia skrutkových spojov a dosadacích ploch konektorov
- všetky nerezové diely je možné čistiť iba vodou, mydlom a jemnou handričkou, v žiadnom prípade nie je možné použiť agresívne a abrazívne čistiace prostriedky
- po vybalení výrobku je potrebné s obalom postupovať podľa zákona o obaloch
- výrobca garantuje, že na výrobok je vydávané prehlásenie o shode v súlade so zákonom č. 22/1997 Sb.

Kontrola stavu napájecí baterie, Kontrola stavu napájacej batérie

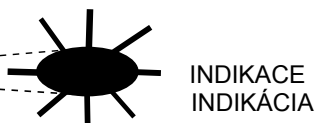
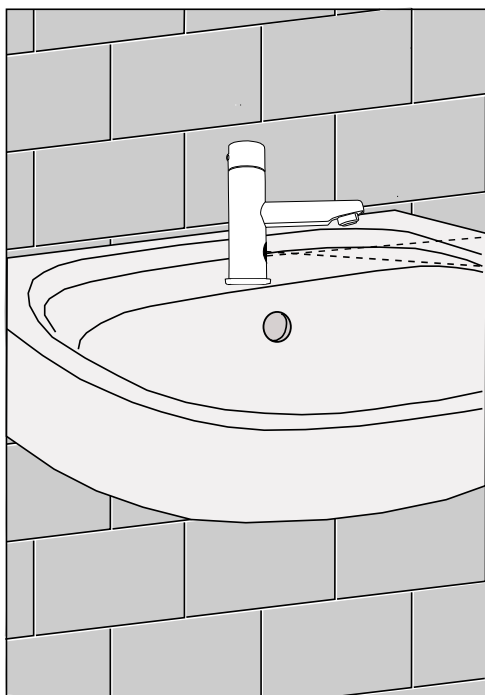

INDIKACE
INDIKÁCIA

TYP BATERIE
Lithiová baterie 9V/1300 mAh
typ U9VL
TYP BATÉRIE:
Lithiová batéria 9V/1300 mAh
typ U9VL

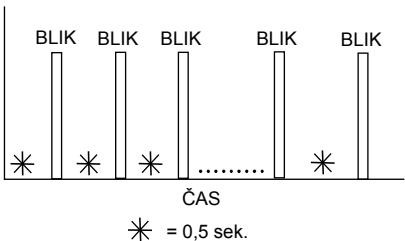
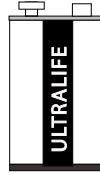
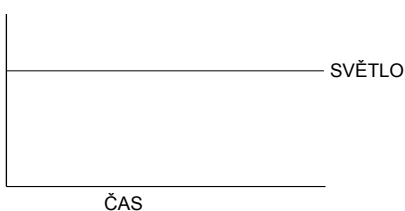
BATERIE	INDIKACE	ELEKTRONICKÝ SYSTÉM	VÝMĚNA BATERIE
 10 ...0 % KAPACITA		ZAPNUT	DOPORUČENÁ
 0 % KAPACITA		VYPNUT	NEZBYTNĚ NUTNÁ

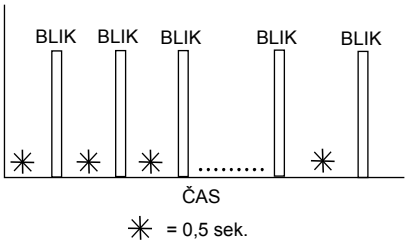
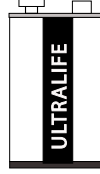
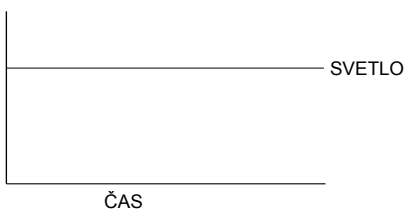
BATÉRIA	INDIKÁCIA	ELEKTRONICKÝ SYSTÉM	VÝMENA BATÉRIE
 10 ...0 % KAPACITA		ZAPNUŤ	DOPORUČENÁ
 0 % KAPACITA		VYPNUŤ	POTREBNÁ